



## VSB College of Engineering Technical Campus

Approved by AICTE, New Delhi & Affiliated to Anna University  
Coimbatore to pollachi Road NH - 209, Ealur Privu, Kinathukadavu Taluk,  
Coimbatore - 642109, Tamilnadu, India. Email: office@vsbcetcc.com Website : www.vsbcetcc.com

### Department of Mechanical Engineering

**Subject Code** : ME6401  
**Subject Name** : KINEMATICS OF MACHINERY

#### UNIT 1 - BASICS OF MECHANISMSPART-

##### A

1. What is Kinematics?
2. Define Link.
3. What is Kinetics?
4. Define Kinematic Pair.
5. Define Kinematic Chain
6. Define Pantograph.
7. What is meant by spatial mechanism?
8. Define Degrees of Freedom.
9. Classify the Constrained motion?
10. What are the important applications of a single slider crank mechanism?
11. What is Toggle position?
12. Give some examples for kinematic pairs.
13. Write down the Grashof's law for a four bar mechanism?
14. What is meant by transmission angle?
15. What are the applications of inversion of double slider crank chain mechanism?

##### PART-B

1. (a) Define Kinematic pair. What is the difference between lower pair and higher pair? Give examples for each type.  
(b) Describe the three inversions of Double slider crank chain with neat sketches.
2. Give diagrammatic sketches of the following mechanisms and state on which Kinematic chain each mechanism is based:
  - i. Oscillating cylinder engine
  - ii. Oldham shaft coupling
  - iii. Pendulums pump
  - iv. Scotch yoke mechanism
  - v. Watt's indicator.
3. (a) Explain watt mechanism and prove that it generates a straight-line motion.  
(b) Why Watt mechanism is so commonly used to generate an approximate straight line motion?
4. Perform the kinematic analysis of the following Exact Straight Line motion mechanisms.
  - (i) Peaucellier Mechanism. (ii) Hart's Mechanism
5. (i) Sketch and explain any three inversions of a Slider crank chain
6. Determine the number of degrees of freedom of the mechanism shown below :



## VSB College of Engineering Technical Campus

Approved by AICTE, New Delhi & Affiliated to Anna University  
Coimbatore to pollachi Road NH - 209, Eatur Privu, Kinathukadavu Taluk,  
Coimbatore - 642109, Tamilnadu, India. Email: office@vsbcetec.com Website : www.vsbcetec.com

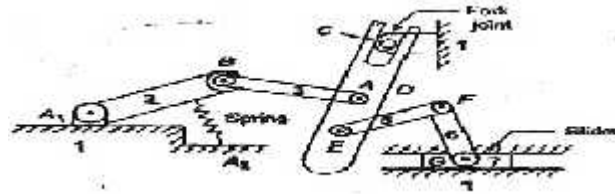

- (ii) Illustrate a crank and slotted lever mechanism as an inversion of single slider crank chain. Deduce an expression for length of stroke in terms of link lengths.
- Draw and explain about Four bar chain
- Define mobility, Kutzbach criterion law, Grashoff's law and prismatic.
- Calculate the degrees of freedom of the mechanisms shown in Figure given below

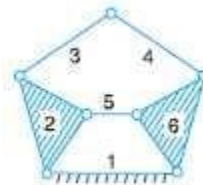

- With the help of a neat sketch explain the working of Whitworth quick return Mechanism

### UNIT II - KINEMATICS OF LINKAGE MECHANISMS PART-A

- Define Instantaneous centre
- What are the important concepts in velocity analysis?
- How to represent the direction of linear velocity of any point on a link with respect to another point on the same link?
- Define displacement.
- Define Kennedy's theorem
- What are the types of motions?
- What are the methods for determining the velocity of a body?
- Define speed.
- Define Acceleration.
- Define velocity
- What is deceleration?
- Define coincident points.
- Define Body centroid.
- Define centroid.
- Define Axode.

### PART-B

- In a simple steam engine, the lengths of the crank and the connecting rod are 100 mm and 400 mm respectively. The weight of the connecting rod is 50 kg and its centre of mass is 220 mm from the cross head centre. The radius of gyration about the centre of mass is 120 mm. If the engine speed is 300 rpm and the crank has turned  $45^\circ$  from IDC, determine (i) The angular velocity and acceleration of the connecting rod (ii) Kinetic energy of the connecting rod.



- PQRS is a four bar chain with a fixed link PS. The lengths of the links are : PQ = 62.5 mm, QR = 175 mm, RS = 112.5 mm and PS = 200 mm. The crank PQ rotates at 10 rad/s clockwise. Draw the velocity and acceleration diagram when angle QPS = 60° and find the angular velocity and angular acceleration of the links QR and RS.
- A four bar chain is represented by a quadrilateral ABCD in which AD is fixed and is 0.6m long. The crank AB=0.3m long rotates in a clockwise direction at 10 rad/sec and with an angular acceleration of 30 rad/s<sup>2</sup>, both clockwise. The crank drives the link CD=0.36m by means of the connecting link BC=0.36m. the angle BAD=60°. Using graphical method, determine the angular velocities and angular accelerations of CD and BC.
- A single slider crank mechanism is shown in fig. Determine the acceleration at B & E and the angular acceleration of the link AB. The crank rotates at 20 red/sec counter- clockwise.

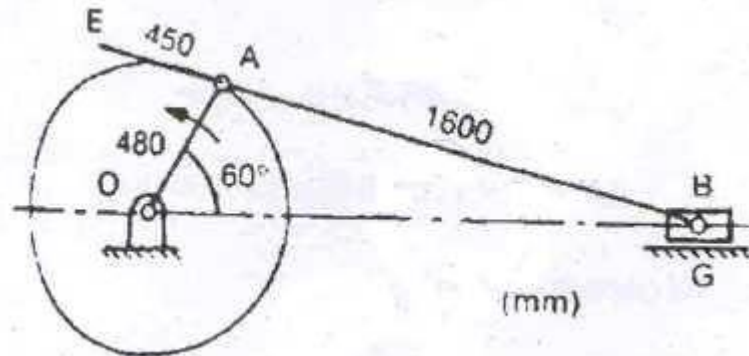

- The following data refer to the dimensions of the links of a four-bar mechanism: AB=50mm; BC=66mm; CD=56mm; and AD(fixed link)=100mm. at the instant when angle DAB=60°, the link AB has an angular velocity of 10.5 rad/s in the counter clockwise direction. Determine the velocity of point C, velocity of point E on the link BC while BE=40mm and the angular velocities of the links BC and CD. also sketch the mechanism and indicate the data.
- The crank of a slider crank mechanism is 15 cm and the connecting rod is 60 cm long. The crank makes 300 rpm in clockwise direction. When it has turned 45° from the inner dead centre position, determine (i) Acceleration of the slider and (ii) Angular acceleration of the connecting rod. (Nov 2015)
- Figure 2 show a mechanism in which OA =300mm, AB=600, AC=1200mm, BD =1200mm. OD is Horizontal for the given configuration. If OA rotates at 200rpm in clockwise direction, find  
(i) the linear velocities of C and D and (ii) the angular velocities of links AC and BD.
- Sketch and explain any three kinematic inversions of four-bar chain.
- In a four bar chain ABCD, AD is fixed and is 15 cm long. The crank AB is 4 cm long and rotates at 120 rpm clockwise, while the link CD (whose length is 8 cm) oscillates about D. BC and AD are of equal length. Find the angular velocity of link CD when angle BAD = 60°.



10. In a mechanism shown in the below figure, the various dimensions are  $OC = 125$  mm;  $CP = 500$  mm;  $PA = 125$  mm;  $AQ = 250$  mm; and  $QE = 125$  mm. The slider P translates along the axis which is 25 mm vertically below point O. The crank OC rotates uniformly at 120 r.p.m in the anti-clockwise direction. The bell crank lever AQE rocks about fixed centre Q. Draw the velocity diagram and calculate the absolute velocity of point E of the lever.

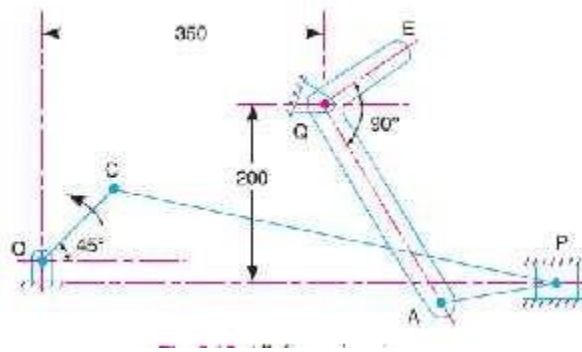

### UNIT-III KINEMATICS OF CAM MECHANISMS

#### PART-A

1. Distinguish radial and cylindrical cams.
2. What is cam?
3. Define tangent cam?
4. Compare Roller and mushroom follower of a cam.
5. What are the different motions of the follower?
6. Define trace point in the study of cams.
7. Define pressure angle with respect to cams
8. Define undercutting in cam. How is occurs?
9. What are the different types of cams?
10. Define Trace point
11. What is meant by Simple Harmonic Motion?
12. Define cam angle.
13. Define Pitch curve

#### PART-B

1. A cam operating a knife edged follower has the following data :
  - (a) Follower moves outwards through 40 mm during  $60^\circ$  of cam rotation
  - (b) Follower dwells for the next  $45^\circ$
  - (c) Follower returns to its original position during next  $90^\circ$
  - (d) Follower dwells for the rest of the rotation.

The displacement of the follower is to take place with Simple Harmonic motion during both the outward and return strokes. The least radius of the cam is 50 mm. Draw the profile of the cam when the axis of the follower passes through the cam axis.



## VSB College of Engineering Technical Campus

Approved by AICTE, New Delhi & Affiliated to Anna University  
Coimbatore to pollachi Road NH - 209, Ealur Privu, Kinathukadavu Taluk,  
Coimbatore - 642109, Tamilnadu, India. Email: office@vsbcetec.com Website : www.vsbcetec.com

2. A cam, with a minimum radius of 50 mm, rotating clockwise at a uniform Speed, is required to give a knife edge follower the motion as described below:
  1. To move outwards through 40 mm during  $100^\circ$  rotation of the cam;
  2. To dwell for next  $80^\circ$ ;
  3. To return to its starting position during next  $90^\circ$ , and 4. To dwell for the rest period of a revolution i.e.  $90^\circ$ .
3. Draw the profile of the cam
  - (i) When the line of stroke of the follower passes through the centre of the cam shaft,
  - (ii) When the line of stroke of the follower is off-set by 15 mm.The displacement of the follower is to take place with uniform acceleration and uniform retardation. Determine the maximum velocity and acceleration of the follower when the cam shaft rotates at 900 r.p.m.  
Draw the displacement, velocity and acceleration diagrams for one complete revolution of the cam.
4. Draw the profile of the cam when the roller follower moves with cycloidal motion during out stroke and return stroke, as given below :
  1. out stroke with maximum displacement of 31.4 mm during  $180^\circ$  of cam rotation,
  2. Return stroke for the next  $150^\circ$  of cam rotation,
  3. Dwell for the remaining  $30^\circ$  of cam rotationThe minimum radius of the cam is 15 mm and the roller diameter of the follower is 10 mm. The axis of the roller follower is offset by 10 mm towards right from the axis of cam shaft.
5. In a symmetrical tangent cam operating a roller follower, the least radius of the cam is 30 mm and roller radius is 17.5 mm. The angle of ascent is  $75^\circ$  and the total lift is 17.5 mm. The speed of the cam shaft is 600 r.p.m.  
Calculate: 1. The principal dimensions of the cam; 2. The accelerations of the follower at the beginning of the lift, where straight flank merges into the circular nose and at the apex of the circular nose. Assume that there is no dwell between ascent and descent.
6. Design a cam to raise a valve with simple harmonic motion through 50 mm in  $1/3$  of a revolution, keep it fully raised through  $1/12$  revolution and to lower it with simple harmonic motion in  $1/6$  revolution. The valve remains closed during the rest of the revolution. The diameter of the roller is 20 mm and the minimum radius of the cam is 25 mm. The diameter of the camshaft is 25 mm. The axis of the valve rod passes through the axis of the camshaft. If the camshaft rotates at uniform speed of 100 r.p.m.; find the maximum velocity and acceleration of a valve during raising and lowering.
7. A cam, with a minimum radius of 25 mm, rotating clockwise at a uniform speed is to be designed to give a roller follower, at the end of a valve rod, motion described below :
  1. To raise the valve through 50 mm during  $120^\circ$  rotation of the cam;
  2. To keep the valve fully raised through next  $30^\circ$ ;
  3. To lower the valve during next  $60^\circ$ ; and
  4. To keep the valve closed during rest of the revolution i.e.  $150^\circ$ ;The diameter of the roller is 20 mm and the diameter of the cam shaft is 25 mm. Draw the profile of the cam when (a) the line of stroke of the valve rod passes through the axis of the cam



shaft, and (b) the line of the stroke is offset 15 mm from the axis of the cam shaft. The displacement of the valve, while being raised and lowered, is to take place with simple Harmonic motion. Determine the maximum acceleration of the valve rod when the cam shaft rotates at 100

r.p.m. Draw the displacement, the velocity and the acceleration diagrams for one complete revolution of the cam.

8. Draw the profile of the cam when the roller follower moves with cycloidal motion during outstroke and return stroke, as given below :

1. out stroke with maximum displacement of 31.4 mm during  $180^\circ$  of cam rotation,
2. Return stroke for the next  $150^\circ$  of cam rotation,
3. Dwell for the remaining  $30^\circ$  of cam rotation.

The minimum radius of the cam is 15 mm and the roller diameter of the follower is 10 mm. The axis of the roller follower is offset by 10 mm towards right from the axis of cam shaft.

9. A symmetrical tangent cam operating a roller follower has the following particulars :

Radius of base circle of cam = 40 mm, roller radius = 20 mm, angle of ascent =  $75^\circ$ , total lift = 20 mm, speed of cam shaft = 300 r.p.m. Determine: 1. the principal dimensions of the cam,

2. the equation for the displacement curve, when the follower is in contact with the straight flank and 3. The acceleration of the follower when it is in contact with the straight flank where it merges into the circular nose.

10. It is required to set out the profile of a cam to give the following motion to the reciprocating follower with a flat mushroom contact face :

- (i) Follower to have a stroke of 20 mm during  $120^\circ$  of cam rotation;
- (ii) Follower to dwell for  $30^\circ$  of cam rotation;
- (iii) Follower to return to its initial position during  $120^\circ$  of cam rotation; and
- (iv) Follower to dwell for remaining  $90^\circ$  of cam rotation.

The minimum radius of the cam is 25 mm. The out stroke of the follower is performed with simple harmonic motion and the return stroke with equal uniform acceleration and retardation.

#### **UNIT IV – GEARS AND GEAR TRAINS PART-**

##### **A**

1. Define normal and axial pitch in helical gears.
2. State law of Gearing.
3. What are the advantages and limitations of gear drive? Write any two.
4. Define interference.
5. Define Backlash.
6. Define cycloidal tooth profile and involute tooth profile
7. Where the epicyclic gear trains are used?
8. Define Contact Ratio.
9. What are the methods to avoid interference?
10. What is the advantage of a compound gear train over a simple gear train?
11. What is the externally applied torques used to keep the gear train in equilibrium?



**PART-B**

1. A toothed gear A is to drive another toothed gear B. The centre to centre distance between their axes of rotation is to be exactly 375 mm. Speed A is to be 500 rpm and that of B is 350 r.p.m. approximately. If each is of module 5 mm. determine what should be the number of teeth on each gear. In that case what would be the actual speed of gear B? Assuming that the gears available have teeth divisible by 5 only
2. Two mating gears have 20 and 40 involute teeth of module 10 mm and  $20^\circ$  pressure angle. The addendum on each wheel is to be made of such a length that the line of contact on each side of the pitch point has half the maximum possible length. Determine the addendum height for each gear wheel, length of the path of contact, arc of contact and contact ratio.
3. Two involute gears of  $20^\circ$  pressure angle are in mesh. The number of teeth on pinion is 20 and the gear ratio is 2. If the pitch expressed in module is 5 mm and the pitch line speed is 1.2 m/s, assuming addendum as standard and equal to one module, find:
  - a. The angle turned through by pinion when one pair of teeth is in mesh; and
  - b. The maximum velocity of sliding.
4. In an epicyclic gear train, an arm carries two gears A and B having 36 and 45 teeth respectively. If the arm rotates at 150 r.p.m. in the anticlockwise direction about the centre of the gear A which is fixed, determine the speed of gear B. If the gear A instead of being fixed, makes 300 r.p.m. in the clockwise direction, what will be the speed of gear B ?
5. In a reverted epicyclic gear train, the arm A carries two gears B and C and a compound gear D - E. The gear B meshes with gear E and the gear C meshes with gear D. The number of teeth on gears B, C and D are 75, 30 and 90 respectively. Find the speed and direction of gear C when gear B is fixed and the arm A makes 100 r.p.m. clockwise.
6. An epicyclic gear consists of three gears A, B and C as shown in Fig. The gear A has 72 internal teeth and gear C has 32 external teeth. The gear B meshes with both A and C and is carried on an arm EF which rotates about the centre of A at 18 r.p.m.. If the gear A is fixed, determine the speed of gears B and C.

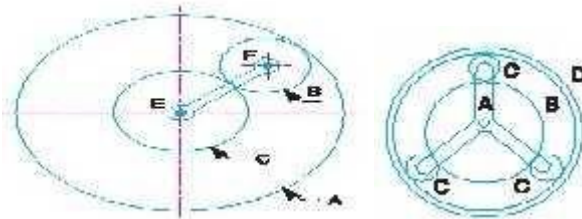

7. In an epicyclic gear of the 'sun and planet' type shown in Fig. the pitch circle diameter of the internally toothed ring is to be 224 mm and the module 4 mm. When the ring D is stationary, the spider A, which carries three planet wheels C of equal size, is to make one revolution in the same sense as the sunwheel B for every five revolutions of the driving spindle carrying the sunwheel B. Determine suitable numbers of teeth for all the wheels.





## VSB College of Engineering Technical Campus

Approved by AICTE, New Delhi & Affiliated to Anna University  
Coimbatore to pollachi Road NH - 209, Ealur Privu, Kinathukadavu Taluk,  
Coimbatore - 642109, Tamilnadu, India. Email: office@vsbcetcc.com Website : www.vsbcetcc.com

8. In an epicyclic gear train a gear C is keyed to the driving shaft A which rotates at 900 rpm. Gears D and E are fixed together and rotate freely on a pin carried by the arm M which is keyed to the driven shaft B. Gear D is in mesh with gear C while the gear E is in mesh with a fixed annular wheel F. The annular wheel is concentric with the driven shaft B. If the shaft A and B are collinear and number of teeth on gears C, D, E and F are respectively 21, 28, 14 and 84. Determine the speed and sense of rotation of the driven shaft B. (Apr/May-2015)
9. Calculate:
  - (i) Length of path of contact
  - (ii) Arc of contact
  - (iii) The contact ratio, when a pinion having 23 teeth drives a gear having teeth 57. The profile of the gears is involute with pressure angle  $20^\circ$ , module 8mm and addendum equal to one module.
10. State and prove the law of gearing. (NOV/DEC-2012)

### UNIT V – FRICTION IN MACHINE ELEMENTS PART-A

1. What are the effects of limiting angle of friction?
2. Define co-efficient of friction ( $\mu$ ).
3. Why self-locking screws have lesser efficiency?
4. What are the functions of clutches? 5. Why friction is called as 'necessary evil'? 6. State the law of belting?
7. What do you mean by 'Crowning in pulley'?
8. List out the commonly used breaks.
9. Write down the disadvantage of V-belt drive over flat belt?
10. Why lubrication reduces friction?
11. When is the cross belt used instead of open belt?

### PART-B

#### Problems on Bearings:

1. Deduce the expression for determination of frictional torque in a conical pivot bearing considering uniform wear. (Nov/Dec 2004)
2. Derive the expression to determine the power lost in trapezoidal (truncated) conical pivot bearing considering uniform pressure condition. (Nov/Dec 2005)
3. In a thrust bearing, the external and internal diameters of the contacting surfaces are 320mm and 200 mm respectively. The total axial load is 80 kN and the intensity of pressure





## VSB College of Engineering Technical Campus

Approved by AICTE, New Delhi & Affiliated to Anna University  
Coimbatore to pollachi Road NH - 209, Ealur Privu, Kinathukadavu Taluk,  
Coimbatore - 642109, Tamilnadu, India. Email: office@vsbcetec.com Website : www.vsbcetec.com

- is  $350 \text{ KN/m}^2$ . The shaft rotates at 400 rpm. Taking the coefficient of friction as 0.06. Calculate the power lost in overcoming the friction and the number of collars required.(Nov/Dec 2012)
- A vertical shaft of 100 mm diameter rotating at 150 rpm rests on a flat end foot step bearing. The coefficient of friction is  $\mu = 0.05$  and shaft carries vertical load of 15 KN. Find the power lost in friction assuming the following conditions (i) Uniform pressure (ii)Uniform wear(May / June 2013)
  - A vertical shaft of 140 mm diameter rotating at 120 rpm, rests on a flat end foot step bearing. The coefficient of friction is  $\mu = 0.06$  and shaft carries vertical load of 30 KN. Find the power lost in friction assuming the following conditions (i) Uniform pressure (ii)Uniform wear(Nov /Dec 2013)
  - A 150 mm valve, against a steam pressure of  $2 \text{ MN/m}^2$  is acting, is closed by means of a square threaded a screw 50 mm in external diameter with 6 mm pitch. If the coefficient of friction is 0.12, find the torque required to turn the handle.(May /June 2014)
  - A load of 25 kN is supported by a conical pivot with angle of cone as  $120^\circ$ . The intensity of pressure is not to exceed  $350 \text{ kN/m}^2$ . The external radius is 2 times the internal radius. The shaft is rotating at 180 rpm and coefficient of friction is 0.05. find the power absorbed in friction assuming uniform pressure.(Nov/Dec 2006)
  - The thrust of a propeller shaft in marine engine is taken up by a number of collars integral with the shaft which is 300 mm in diameter. The thrust on the shaft is 200 KN and the speed is 75 rpm. Taking  $\mu=0.05$  and assuming intensity of pressure as uniform and equal to  $0.3 \text{ N/mm}^2$ , find the external diameter of the collars and the number of collars required, if the power lost in friction is not to exceed 16kW.(May /June 2007)
  - A conical pivot bearing supports a vertical shaft of 200 mm diameter. It is subjected to a load of 30 kN. The angle of cone is  $120^\circ$  and the coefficient of friction is 0.025. Find the power lost in friction when the speed is 140 rpm assuming :(i) uniform pressure and (ii) uniform wear. (Nov/Dec 2004)
  - A conical pivot bearing 150 mm in diameter has a cone angle of  $120^\circ$ . If the shaft supports an axial load of 20 kN and the coefficient of friction is 0.03, find the power lost in friction when the shaft rotates at 200 rpm. (Assume uniform wear condition).(Apr/May2006)
  - A truncated conical pivot of cone angle  $\phi$  rotating at speed N, supports a load W. the smallest and largest diameter of the pivot over the contact area are 'd' and D respectively. Assuming uniform wear, derive the expression for the frictional torque.(Apr/May 2006)
  - A conical pivot supports a load of 20 kN, the cone angle is  $120^\circ$  and the intensity of normal pressure is not to exceed  $0.3 \text{ N/mm}^2$ . The external diameter is twice the internal diameter. Find the outer and inner radii of the bearing surface. If the shaft rotates at 200 rpm and the coefficient of friction is 0.1, find the power absorbed in friction. Assume uniform pressure.(Nov/Dec 2005)



**Problems on Clutches:**

1. The external and internal radii of a friction plate of a single plate of a single clutch are 120 mm and 60 mm respectively. The friction surfaces are held together with a total axial thrust of 1500 N. For uniform wear; find the maximum, minimum and average pressure on the contact surface. (Apr/May 2006)
2. A cone clutch is to transmit 7.5 Kw at 900 rpm. The cone has a face angle of  $12^\circ$ . The width of the face is half of the mean radius and the normal pressure between the contact faces is not to exceed  $0.09 \text{ N/mm}^2$ . Assuming uniform wear condition and the coefficient of friction between contact faces as 0.2, find the main dimensions of the clutch and the axial force required to engage the clutch. (NOV/DEC 2002)
3. A single dry plate clutch transmits 7.5 kW at 900 revolutions per minute. The axial pressure is limited to  $0.07 \text{ N/mm}^2$ . If the coefficient of friction is 0.25, find (i) mean radius and face width of the friction lining assuming the ratio of the mean radius to the face width as 4, and (ii) outer and inner radii of the clutch plate. (Apr/May 2005) (May / June 2009)
4. A 10 kW engine develops a maximum torque of 100 N.m and is driving a car having a single plate clutch of two active surfaces. Axial pressure is not to exceed 0.85 bar. External diameter of friction plate is 1.25 times internal diameter. Assume uniform wear and coefficient of friction = 0.3. Determine dimension of friction plate and axial force exerted by the springs. (Nov/Dec 2006)
5. A rotor is driven by a co-axial motor through a single plate clutch, both sides of the plate being effective. The external and internal diameters of the plate are respectively 220 mm and 160 mm and the total spring load pressing the plates together is 570 N. The motor armature and shaft has a mass of 800 kg with an effective radius of gyration of 200 mm. The rotor has a mass of 1300 kg with an effective radius of gyration of 180 mm. The coefficient of friction for the clutch is 0.35. The driving motor is brought up to a speed of 1250 rpm when the current is switched off and the clutch suddenly engaged. Determine  
(i) the final speed of motor and rotor, (ii) the time to reach this speed, (iii) the kinetic energy lost during the period of slipping. (Nov/Dec 2011)
6. A single plate clutch has dimensions 300 mm outside diameter and 100 mm inside diameter. Both sides of the plate are effective. Assuming uniform wear and coefficient of friction of 0.35, determine the maximum power that can be transmitted at 1500 rpm, if the maximum pressure on the plate is not to exceed  $1 \text{ MN/m}^2$ . Find also the minimum intensity of pressure and its location. (Nov/Dec 2011)
7. A single plate clutch, with both sides effective, has outer and inner diameters 300 mm and 200 mm respectively. The maximum intensity of pressure at any point in the contact surface is not to exceed  $0.1 \text{ N/mm}^2$ . If the coefficient of friction is 0.3, determine the power transmitted by a clutch at a speed 2500 rpm for two types assumptions, that is for uniform pressure and uniform wear. (Apr /May 2012)



## VSB College of Engineering Technical Campus

Approved by AICTE, New Delhi & Affiliated to Anna University  
Coimbatore to pollachi Road NH - 209, Ealur Privu, Kinathukadavu Taluk,  
Coimbatore - 642109, Tamilnadu, India. Email: office@vsbcetec.com Website : www.vsbcetec.com

8. A friction clutch of multi plate types is meant for transmitting a power of 55 KW at 1800 rpm. Coefficient of friction for the friction surfaces is 0.1. Axial intensity of pressure is not to exceed 160 KN/m<sup>2</sup>. The internal radius is 80 mm and is 0.7 times the external radius. Determine the number of plates needed to transmit the required torque.(May / June 2013)(Nov /Dec 2013)
9. A leather faced conical clutch has a cone angle of 30°. If the intensity of pressure between the contact surfaces is limited to 0.35 N/mm<sup>2</sup> and the breadth of the conical surface is not to exceed 1/3<sup>rd</sup> of the mean radius, determine the dimensions of the contact surfaces to transmit 22.5 kW at 2000 rpm. Assume uniform wear rate and  $\mu = 0.15$ (May /June 2007) (May /June 2008)
10. Derive the expression for frictional torque on cone clutch based on uniform pressure theory.(May /June 2007)
11. Derive the expression for frictional torque on cone clutch based on uniform wear theory.(May /June 2007)

### Problems on Screw jack:

1. Derive an expression for maximum efficiency of a screw jack.(Nov/Dec 2011& 2009)
2. The following data related to the screw jack: pitch of the threaded screw = 8 mm; diameter of the screw thread = 40 mm; coefficient of friction between screw and nut = 0.1; load 20kN. Assuming that the load rotates with screw, determine (i) the ratio of torques required to raise and lower the load, and (ii) the efficiency of the machine.(Apr /May 2012)
3. The mean diameter of the screw jack having pitch of 10 mm is 50 mm. a load of 20 kN is lifted through a distance of 170 mm. find the workdone in lifting the load and efficiency of the screw jack when (i) the load rotates with the screw, and (ii) the load rests on the loose head which does not rotate with the screw. The external and internal diameters of the bearing surface of the loose head are 60 mm and 10 mm respectively. The coefficient of friction for the screw as well as the bearing surface may be taken as 0.08. (Nov/Dec 2011)
4. A load of 10 KN is raised by means of a screw jack, having a square threaded screw of 12mm pitch and of mean diameter 50 m. if a force of 100 N is applied at the end of a lever to raise the load, what should be the length of the lever used? Coefficient of friction is 0.15. What is the mechanical advantage obtained? State whether the screw is self locking or not. (May/June 2009)
5. A vertical screw with single start square thread 50 mm mean diameter and 10 mm pitch is raised against a load of 5500 N by means of a hand wheel, the boss of which is threaded to act as a nut. The axial load is taken up by a thrust collar which supports the wheel boss and has a mean diameter of 65 mm. if the coefficient of friction is 0.15 for the screw and 0.18 for the collar and tangential force applied by each hand to the wheel is 140 N, find the suitable diameter of the hand wheel.(NOV/DEC 2002)



## VSB College of Engineering Technical Campus

Approved by AICTE, New Delhi & Affiliated to Anna University  
Coimbatore to pollachi Road NH - 209, Ealur Privu, Kinathukadavu Taluk,  
Coimbatore - 642109, Tamilnadu, India. Email: office@vsbcetec.com Website : www.vsbcetec.com

6. A bolt is having V-threads. The pitch of the threads is 5 mm and V-angle is  $55^\circ$ . The mean diameter of the bolt is tightened by screwing a nut. The mean radius of the bearing surface of the nut is 25 mm. the load on the bolt is 5000 N. The coefficient of friction for nut and bolt is 0.1 whereas for nut and bearing surface is 0.16. Determine the force required at the end of a spanner 0.6 m long. (Apr/May2003)
7. The efficiency of a screw jack is 55%, when a load of 1500 N is lifted by an effort applied at the end of a handle of length 0.5m. Determine the effort applied if the pitch of the screw thread is 10 mm.(Nov/Dec 2003)
8. Derive from first principles an expression for the effort required to raise a load with a screw jack taking friction into consideration.(Nov/Dec 2004 & 2005),(Apr/May2006)(May /June 2008)
9. The mean diameter of the screw jack having pitch of 10 mm is 50 mm. A load of 20 KN is lifted through a distance of 170 mm. find the workdone in lifting the load and efficiency of the screw jack when: (i) the load rotates with screw, and (ii) the load rests on the loose head which does not rotate with the screw. The external and internal diameter of the bearing surface of the loose head is 60 mm and 10 mm respectively. The coefficient of friction for the screw as well as the bearing surface may be taken as 0.08(Apr/May2005)
10. A square threaded bolt of root diameter 22.5 mm and pitch 5 mm is tightened by screwing nut whose mean diameter of bearing surface is 50 mm. if coefficient of friction for nut and bolt is 0.1 and for nut and bearing surface 0.16, find the force required at the end of a spanner 500 mm long when the load on the bolt is 10 kN. (Nov/Dec 2005),(Apr/May 2006),(May /June 2007)(Nov/Dec 2007),
11. A screw –jack has a square thread of mean diameter 6 cm and pitch 0.8 cm. the coefficient of friction at the screw is 0.09. a load of 3 KN is to be lifted through 12 cm. determine the torque required and workdone in lifting the load through 12 cm. find the efficiency of the jack also.(Nov/Dec 2006)
12. A pitch of 50 mm dia threaded screw of a screw jack is 12.5 mm. Coefficient of friction between screw and nut is 0.10. Determine the torque required to raise the load of 25 kN rotating with screw. Also find the torque required to lower the load and efficiency.(Nov/Dec 2006)
13. A 150 mm diameter valve, against a steam pressure of  $2 \text{ MN/m}^2$  is acting, is closed by means of a square threaded screw 50 mm in external diameter with 6 mm pitch. If the coefficient of friction is 0.12, find the torque required to turn the handle.(Nov/Dec 2004)

### Problems on Belts:

1. Prove that at the limiting condition of tensions in a flat belt drive is given by the equation

$$\frac{T_1}{T_2} = e^{\mu\theta} \quad (\text{Nov/Dec 2011})$$



## VSB College of Engineering Technical Campus

Approved by AICTE, New Delhi & Affiliated to Anna University  
Coimbatore to pollachi Road NH - 209, Ealur Privu, Kinathukadavu Taluk,  
Coimbatore - 642109, Tamilnadu, India. Email: office@vsbcetcc.com Website : www.vsbcetcc.com

2. 100 kW is to be transmitted by a rope drive through a 160 cm diameter  $45^\circ$  grooved pulley running at 200 rpm. Angle of overlap is  $140^\circ$  and coefficient of friction between pulley and rope is 0.25. mass of the rope is 0.7 kg/m and it can withstand a tension of 8000 N. considering centrifugal tension, find the following: (i) number of ropes required  
(ii) initial tension in the rope.(Nov/Dec 2006)
3. Explain the following: (i) Crowning of pulleys (ii) Self- locking pulleys (iii) uses of brakes in automobiles.(Nov/Dec 2006)
4. A rope drive is required to transmit 230 kW from a pulley of 1 m diameter running at 450rpm. The safe pull in each rope is 800 N and mass of the rope is 0.46 kg/m. The angle of lap and groove angle are  $160^\circ$  and  $45^\circ$  respectively. If the coefficient of friction between the rope and the pulley is 0.3, find the number of ropes required.(Nov/Dec 2011& 2009)
5. Derive an expression for the centrifugal tension in a belt passing round a pulley rim(Nov/Dec 2012) (Apr /May 2010)
6. A pulley is driven by a flat belt, angle of lap being 120 degrees. The weights 6N per meter run. The coefficient of friction is 0.3 and maximum stress in the belt is not to exceed 200 N/cm<sup>2</sup>. The belt is 10 cm wide and 0.6 cm thick. Find the maximum power that can be transmitted and the corresponding speed of the belt(Apr /May 2010)
7. Find the power transmitted by a belt running over a pulley 700 mm diameter at 300 rpm,  $\mu=0.3$  and angle of lap  $160^\circ$  and maximum tension in the belt is 2.453 KN.(May / June 2013)
8. Two pulleys, one 450 mm diameter and the other 200 mm diameter are in parallel shafts 1.95 m apart and are connected by a crossed belt. Find the length of the belt required and angle of contact between the belt and each pulley. What power can be transmitted by the belt when the large pulley rotates at 200 rpm, if the maximum permissible tension in the belt is 1KN and coefficient of friction between the belt and pulley is 0.25?(May /June 2014)
9. A compressor requires 90kW to operate at 250 rpm. The drive is by V-belts from an electric motor running at 750 rpm. The diameter of the pulley on the compressor shaft must not be greater than 1 meter while the center distance between the pulleys is limited to 1.75 m. the belt speed should not exceed 1600 m/min. determine the number of V-beltsrequired to transmit the power if each belt has a cross- sectional area of 375 mm<sup>2</sup>, density1000 kg/m<sup>3</sup> and an allowable tensile stress of 2.5 MPa. The groove angle of the pulley is  $35^\circ$ . The coefficient of friction between the belt and the pulley is 0.25. also calculate the length of belt.(Nov/Dec 2008) (Apr /May 2010)
10. An open belt drive connects two pulleys 120 cm and 50 cm diameters on parallel shafts 4 m apart. The maximum tension in the belt is 1855 N. the coefficient of friction is 0.3. the driver pulley of diameter 120 cm runs at 200 rpm calculate (i) power transmitted (ii) torque on each of two shafts.(May /June 2008)
11. Determine the width of a 9.75 mm thick leather belt required to transmit 15 kW from a motor running at 900 rpm. The diameter of the driving pulley is 300 mm. the driven pulley runs at 300 rpm and the distance between the centers of two pulleys is 3 m. the



## VSB College of Engineering Technical Campus

Approved by AICTE, New Delhi & Affiliated to Anna University  
Coimbatore to pollachi Road NH - 209, Ealur Privu, Kinathukadavu Taluk,  
Coimbatore - 642109, Tamilnadu, India. Email: office@vsbcetc.com Website : www.vsbcetc.com

density of the leather can be taken as  $1000 \text{ kg/m}^3$ . Take  $\mu = 0.3$  and maximum allowable shear in the leather =  $2.5 \text{ MPa}$  and the drive is open type.(Nov/Dec 2007)

12. A leather belt is required to transmit  $7.5 \text{ kW}$  from a pulley  $1.2 \text{ m}$  in diameter, running at  $250 \text{ rpm}$ . The angle embraced is  $165^\circ$  and the coefficient of friction between the belt and pulley is  $0.3$ . If safe working stress for the leather belt is  $1.5 \text{ MPa}$ , density of leather is  $1 \text{ Mg/m}^3$  and thickness of belt is  $10 \text{ mm}$ . determine the width of the belt taking centrifugal tension into account.(May /June 2007)
13. Briefly explain the following: slip of the belt and creep of the belt.(Apr/May2003)
14. An open belt drive connects two pulleys of  $1.2 \text{ m}$  and  $0.5 \text{ m}$  diameters on parallel shaft  $4 \text{ m}$  apart. The maximum tension in the belt is  $1800 \text{ N}$ . the coefficient of friction is  $0.3$ . The driven pulley of diameter  $1.2 \text{ m}$  runs at  $250 \text{ rpm}$ . Calculate the length of the belt required, the power transmitted, and the torque on each of the two shafts.(Apr/May2003)
15. Prove or disprove the following statement: A V-belt drive with same coefficient of friction and angle of wrap as a flat-belt drive will transmit less power than flat-belt drive.(Nov/Dec 2003)
16. Two pulleys, one  $450 \text{ mm}$  diameter and the other  $200 \text{ mm}$  diameter are on parallel shafts  $2.1 \text{ m}$  apart and are connected by a crossed belt. The larger pulley rotates at  $225 \text{ rpm}$ . The maximum permissible tension in the belt is  $1 \text{ kN}$  and the coefficient of friction between the belt and the pulley is  $0.25$ . Find the length of the belt required and the power that can be transmitted.(Nov/Dec 2003)
17. An open belt running over two pulleys of  $1.5 \text{ m}$  and  $1.0 \text{ m}$  diameters connects two parallel shafts  $4.80 \text{ m}$  apart. The initial tension in the belt is  $3000 \text{ N}$ . the smaller pulley is rotating at  $600 \text{ rpm}$ . The mass of belt is  $0.6703 \text{ kg/m}$  length. The coefficient of friction between the belt and pulley is  $0.3$ . Find: (i) the exact length of the belt required, and (ii) the power transmitted taking centrifugal tension into account.(Apr/May 2006),(Nov/Dec 2006)

### Problems on Friction:

1. Derive the force analysis of a body resting on an inclined plane with force inclined to the plane.(Nov /Dec 2013)
2. List out the various types of friction.(Nov /Dec 2013)
3. Prove or disprove the following statement: "Angle of friction is equal to angle of repose". (Apr/May2003)
4. An effort of  $1200 \text{ N}$  is required to just move a certain body up an inclined plane of angle  $12^\circ$  with force acting parallel to the plane. If the angle of inclination is increased to  $15^\circ$ , then the effort required is  $1400 \text{ N}$ . find the coefficient of friction and the weight of the body.(Nov/Dec 2003)



## VSB College of Engineering Technical Campus

Approved by AICTE, New Delhi & Affiliated to Anna University  
Coimbatore to pollachi Road NH - 209, Ealur Privu, Kinathukadavu Taluk,  
Coimbatore - 642109, Tamilnadu, India. Email: office@vsbcetc.com Website : www.vsbcetc.com

### CE8395 - STRENGTH OF MATERIALS FOR MECHANICAL ENGINEERS

#### Part A, B & C - QUESTION BANK

#### UNIT I

#### STRESS STRAIN DEFORMATION OF SOLIDSPART- A

(2 Marks)

1. What is Hooke's Law?
2. What are the Elastic Constants?
3. Define Poisson's Ratio.
4. Define: Resilience
5. Define proof resilience
6. Define modulus of resilience.
7. Define principal planes and principal stresses. (APRIL/MAY 2019)
8. Define stress and strain. (APRIL/MAY 2021)
9. Define Shear stress and Shear strain.
10. Define elastic limit.
11. Define volumetric strain.
12. Define tensile stress and compressive stress.
13. Define young's Modulus.
14. What is the use of Mohr's circle? (APR/MAY 2017)
15. Define thermal stress.
16. Define Bulk modulus.
17. What is modulus of rigidity?
18. Define factor of safety.
19. State the relationship between young's modulus and modulus of rigidity..
20. What is compound bar?
21. What is meant by thermal stresses? (NOV/DEC 2019 & APRIL/MAY 2019)
22. A material has a Young's modulus of  $1.25 \times 10^5$  N/mm<sup>2</sup> and a poisson's ratio of 0.25.  
Calculate the modulus of rigidity. (NOV/DEC 2019)
23. What is principle of super position? (APRIL/MAY 2021)
24. Give the relationship between modulus of elasticity and young's modulus. (APR/MAY2018)





## VSB College of Engineering Technical Campus

Approved by AICTE, New Delhi & Affiliated to Anna University  
Coimbatore to pollachi Road NH - 209, Ealur Privu, Kinathukadavu Taluk,  
Coimbatore - 642109, Tamilnadu, India. Email: office@vsbcetec.com Website : www.vsbcetec.com

### PART- B (13 Marks)

1. A Mild steel rod of 20 mm diameter and 300 mm long is enclosed centrally inside a hollow copper tube of external diameter 30 mm and internal diameter 25 mm. The ends of the rod and tube are brazed together, and the composite bar is subjected to an axial pull of 40 kN. If  $E$  for steel and copper is 200 GN/m<sup>2</sup> and 100 GN/m<sup>2</sup> respectively, find the stresses developed in the rod and the tube also find the extension of the rod.
2. A cast iron flat 300 mm long and 30 mm (thickness)  $\times$  60 mm (width) uniform cross section, is acted upon by the following forces : 30 kN tensile in the direction of the length 360 kN compression in the direction of the width 240 kN tensile in the direction of the thickness. Calculate the direct strain, net strain in each direction and change in volume of the flat. Assume the modulus of elasticity and Poisson's ratio for cast iron as 140 kN/mm<sup>2</sup> and 0.25 respectively.
3. A bar of 30 mm diameter is subjected to a pull of 60 kN. The measured extension on gauge length of 200 mm is 0.09 mm and the change in diameter is 0.0039 mm. calculate the Poisson's ratio and the values of the three modulus.
4. The bar shown in fig. is subjected to a tensile load of 160 kN. If the stress in the middle portion is limited to 150 N/mm<sup>2</sup>, determine the diameter of the middle portion. Find also the length of the middle portion if the total elongation of the bar is to be 0.2 mm.  
5. young's modulus is given as equal to  $2.1 \times 10^5$  N/mm<sup>2</sup>. (APRIL/MAY 2021)

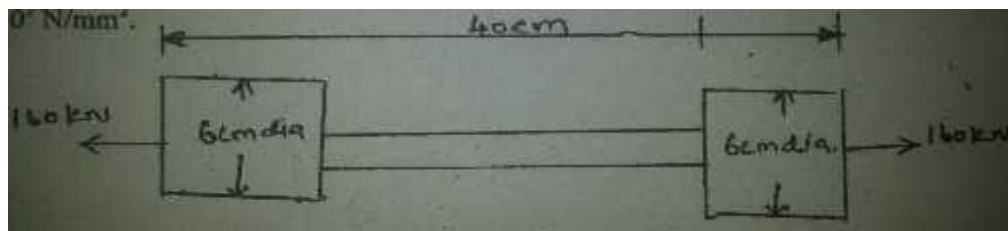

5. A member ABCD is subjected to point loads P<sub>1</sub>, P<sub>2</sub>, P<sub>3</sub>, P<sub>4</sub> as shown in fig. calculate the force P<sub>2</sub> necessary for equilibrium, if P<sub>1</sub> = 45 kN, P<sub>3</sub> = 450 kN and P<sub>4</sub> = 139 kN.



## VSB College of Engineering Technical Campus

Approved by AICTE, New Delhi & Affiliated to Anna University  
 Coimbatore to pollachi Road NH - 209, Ealur Privu, Kinathukadavu Taluk,  
 Coimbatore - 642109, Tamilnadu, India. Email: office@vsbcetec.com Website : www.vsbcetec.com

6. Determine the total elongation of the member, assuming the modulus of elasticity to be

$$2.1 \times 10^5 \text{ N/mm}^2$$

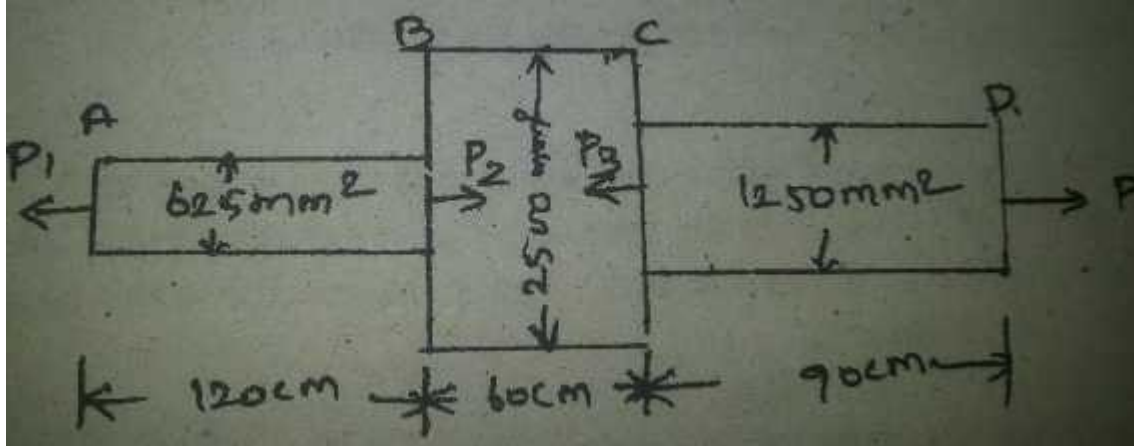

7. A steel rod of 20mm diameter passes centrally through a copper tube of 50mm external diameter and 40mm internal diameter. The tube is closed at each end by rigid plates of negligible thickness. The nuts are tightened lightly home on the projecting parts of the rod. If the temperature of the assembly is raised by 50°C, calculate the stress developed in

copper and steel. Take  $E$  for steel and copper as  $200 \text{ GN/m}^2$  and  $100 \text{ GN/m}^2$  and  $\alpha$  of steel and copper as  $12 \times 10^{-6}$  per °C and  $18 \times 10^{-6}$  per °C.

8. Two vertical rods one of steel and the other of copper are each rigidly fixed at the top and 50cm apart. Diameters and lengths of each rod are 2cm and 4m respectively. A cross bar fixed to the rods at the lower ends carries a load of 5000 N such that the cross bar remains horizontal even after loading. Find the stress in each rod and the position of the

load on the bar. Take  $E$  for steel =  $2 \times 10^5 \text{ N/mm}^2$  and  $E$  for copper =  $1 \times 10^5 \text{ N/mm}^2$ .

9. Drive the relationship between modulus of elasticity and modulus of rigidity.

10. Calculate the modulus of rigidity and bulk modulus of a cylindrical bar of diameter 30 mm and of length 1.5 m if the longitudinal strain in a bar during a tensile stress is four times the lateral strain. Find the change in volume, when the bar is subjected to a

hydrostatic pressure of  $10 \text{ N/mm}^2$ . Take  $E = 1 \times 10^5 \text{ N/mm}^2$



## VSB College of Engineering Technical Campus

Approved by AICTE, New Delhi & Affiliated to Anna University  
Coimbatore to pollachi Road NH - 209, Ealur Privu, Kinathukadavu Taluk,  
Coimbatore - 642109, Tamilnadu, India. Email: office@vsbcetec.com Website : www.vsbcetec.com

11. Find the young's modulus of a rod of diameter 30 mm and of length 300 mm which is subjected to a tensile load of 60 KN and the extension of the rod is equal to 0.4 mm.
12. The ultimate stress for a hollow steel column which carries an axial load of 2MN is  $500 \frac{2}{\text{N}}/\text{mm}$ . If the external diameter of the column is 250mm, determine the internal diameter Take the factor of safety as 4.0
13. The extension in a rectangular steel bar of length 400 mm and thickness 3 mm is found be 0.21 mm .The bar tapers uniformly in width from 20 mm to 60 mm E for the bar is  $2 \times 10^5 \frac{2}{10} \text{ N/mm}$  .Determine the axial load on the bar.
14. A steel rod of 3 cm diameter and 5 m long is connected to two grips and the rod is maintained at a temperature of  $95^{\circ} \text{C}$ . Determine the stress and pull exerted when the temperature falls to  $30^{\circ} \text{C}$ , if (i) the ends do not yield, and (ii) the ends yield by 0.12 cm. Take  $E = 2 \times 10^5 \text{ MN/m}^2$  and  $\alpha = 12 \times 10^{-6} / ^{\circ} \text{C}$ .  
**(APRIL/MAY 2019)**
15. An elemental cube is subjected to tensile stresses of  $30 \text{ N/mm}^2$  and  $10 \text{ N/mm}^2$  acting on two mutually perpendicular planes and a shear stress of  $10 \text{ N/mm}^2$  on these planes. Draw the Mohr's circle of stresses and hence or otherwise determine the magnitudes of directions of principal stresses and also the greatest shear stress. **(APRIL/MAY 2019)**
16. A steel bolt 25 mm diameter and 30 cm long passes through a copper tube having internal and external diameters of 30 mm and 40 mm respectively. The bolt has 4 threads per cm and the nut is initially tight. Calculate (i) the angle through which nut is turned through to cause a tensile stress of 80 MPa in the bolt, (ii) stress in the tube, and (iii) the change instress in the bolt and the tube due to an increase in temperature of  $300^{\circ} \text{C}$ . Young's modulus of steel = 200 GPa, Young's modulus of copper = 100 GPa, Coefficient of linearexpansion for steel =  $10 \times 10^{-6} \text{ per } ^{\circ} \text{C}$ , Coefficient of linear expansion for copper =  $15 \times 10^{-6} \text{ per } ^{\circ} \text{C}$ .  
**(NOV/DEC 2019)**



## VSB College of Engineering Technical Campus

Approved by AICTE, New Delhi & Affiliated to Anna University  
Coimbatore to pollachi Road NH - 209, Ealur Privu, Kinathukadavu Taluk,  
Coimbatore - 642109, Tamilnadu, India. Email: office@vsbcetcc.com Website : www.vsbcetcc.com

17. A steel rod of 3 cm diameter is enclosed centrally in a hollow copper tube of external diameter 5 cm and internal diameter of 4 cm as shown in fig. The composite bar is then subjected to an axial pull of 4500 N. If the length of each bar is equal to 15 cm, determine:
- (i) The stresses in the rod and tube, and (ii) Load carried by each bar. Take  $E$  for steel =  $2.1 \times 10^5 \text{ N/mm}^2$  and for copper =  $1.1 \times 10^5 \text{ N/mm}^2$ .

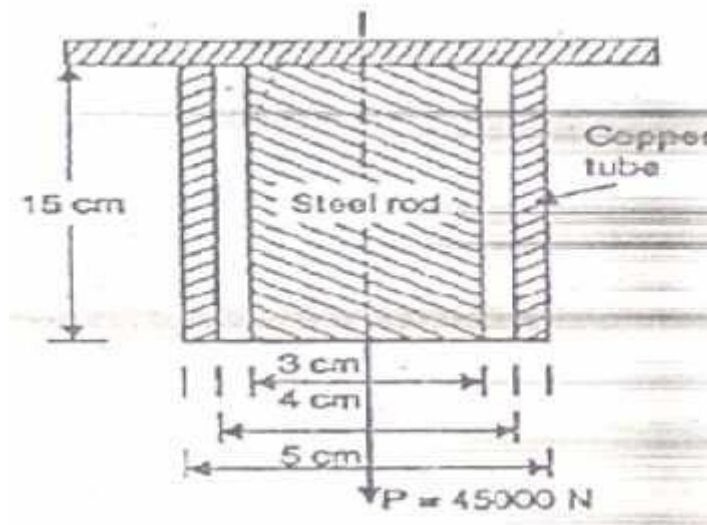

18. A metallic bar 300 mm x 100 mm x 40 mm is subjected to a force of 50 kN (tensile), 6 kN (tensile) and 4 kN (tensile) along x, y and z directions respectively. Determine the change in the volume of the block. Take  $E = 2 \times 10^5 \text{ N/mm}^2$  and Poisson's ratio = 0.25.
19. At a point in a strained material the principal stresses are  $100 \text{ N/mm}^2$  (tensile) and  $60 \text{ N/mm}^2$  (compressive). Determine the normal stress, shear stress and resultant stress on a plane inclined at  $50^\circ$  to the axis of major principal stress. Also determine the maximum shear stress at the point. (NOV/DEC 2017)
20. A load of 2MN is applied on a short concrete column 500 mm x 500 mm. The column is reinforced with four steel bars of 10 mm diameter, one in each corner. Find the stresses in concrete and the steel bars. Take  $E$  for steel =  $2.1 \times 10^5 \text{ N/mm}^2$  and for concrete =  $1.4 \times 10^5 \text{ N/mm}^2$ . (NOV/DEC 2017)
21. A bar of 30 mm diameter is subjected to a pull of 60 kN. The measured extension on gauge length of 200 mm is 0.1 mm and change in diameter is 0.004 mm. Calculate: (APR/MAY 2017) (i) Young's modulus (ii) Poisson's ratio and (iii) Bulk modulus.



## VSB College of Engineering Technical Campus

Approved by AICTE, New Delhi & Affiliated to Anna University  
Coimbatore to pollachi Road NH - 209, Ealur Privu, Kinathukadavu Taluk,  
Coimbatore - 642109, Tamilnadu, India. Email: office@vsbcetec.com Website : www.vsbcetec.com

22. A steel bar 20 mm in diameter, 2 m long is subjected to an axial pull of 50 kN. If  $E = 2 \times 10^5 \text{ N/mm}^2$  and  $\mu = 0.3$ . Calculate the change in (1) length, (2) diameter and (3) Volume.
23. A mild steel bar 20 mm in diameter and 40 cm long is encased in a brass tube whose external diameter is 30 mm and internal diameter is 25 mm. The composite bar is heated through  $80^\circ\text{C}$ . Calculate the stresses induced in each metal,  $\alpha$  for steel and brass as  $11.2 \times 10^{-6} \text{ per } ^\circ\text{C}$  and  $16.5 \times 10^{-6} \text{ per } ^\circ\text{C}$ . Take  $E$  for steel =  $2 \times 10^5 \text{ N/mm}^2$  and for brass =  $1 \times 10^5 \text{ N/mm}^2$ .
24. At a certain point in a strained material, the intensities of stresses on two planes at right angles to each other are  $20 \text{ N/mm}^2$  and  $10 \text{ N/mm}^2$  both tensile. They are accompanied by a shear stress of magnitude  $10 \text{ N/mm}^2$ . Find the location of principal plane and evaluate the principal stresses. (APRIL/MAY 2021)
25. A tensile test was conducted on a mild steel bar. The following data was obtained from the test.
- i) Diameter of the steel bar = 3 cm
  - ii) gauge length of the bar = 20 cm
  - iii) load at elastic limit = 250 kN
  - iv) Extension at a load of 150 kN = 0.21 mm
  - v) maximum load = 380 kN
  - vi) Total extension = 60 mm
  - vii) Diameter of rod at failure = 2.25 cm
- Determine : 1) The young's modulus (2) The stress at elastic limit (3) The percentage of elongation (4) The percentage decrease in area. (APRIL/MAY 2021)



## VSB College of Engineering Technical Campus

Approved by AICTE, New Delhi & Affiliated to Anna University  
Coimbatore to pollachi Road NH - 209, Ealur Privu, Kinathukadavu Taluk,  
Coimbatore - 642109, Tamilnadu, India. Email: office@vsbcetcc.com Website : www.vsbcetcc.com

### UNIT II

#### TRANSVERSE LOADS ON BEAMS AND STRESSES IN BEAMSPART- A (2

#### Marks)

1. State the different types of supports.
2. What is cantilever beam?
3. Write the equation for the simple bending theory.
4. Define shear force and bending moment.
5. What is Shear stress diagram?
6. What is Bending moment diagram?
7. What are the different types of loading?
8. Write the assumption in the theory of simple bending. (NOV/DEC 2019)
9. Write down relations for maximum shear force and bending moment in case of a cantilever beam subjected to uniformly distributed load running over entire span.
10. Draw the shear force diagram for a cantilever beam of span 4 m and carrying a point load of 50 kN at mid span.
11. Sketch (a) the bending stress distribution (b) shear stress distribution for a beam of I section. (NOV/DEC 2019)
12. A cantilever beam 3 m long carries a load of 20 kN at its free end. Calculate the shear force and bending moment at a section 2 m from the free end.
13. A clockwise moment  $M$  is applied at the free end of a cantilever. Draw the SF and BM diagrams for the cantilever.
14. What is maximum bending moment in a simply supported beam of span 'L' subjected to UDL of 'w' over entire span?
15. Draw the S.F. and B.M. diagrams for a cantilever of length  $L$  carrying a point load  $W$  at the free end. (NOV/DEC 2017)
16. What is meant by flitched beam? (NOV/DEC 2017)
17. What do you mean by the point of contraflexure? (APR/MAY 2017) (APR/MAY 2019)
18. What is meant by shear stress in beam? (APR/MAY 2017)
19. List out the assumptions used to derive the simple bending equation.
20. Draw shear force diagram for a simply supported beam of length 4 m carrying a central point load of a kN. (APR/MAY 2017)
21. What are the advantages of flitched beam?
22. What are the types of beams?
23. Derive relationship between bending moment and shear force.



## VSB College of Engineering Technical Campus

Approved by AICTE, New Delhi & Affiliated to Anna University  
Coimbatore to pollachi Road NH - 209, Ealur Privu, Kinathukadavu Taluk,  
Coimbatore - 642109, Tamilnadu, India. Email: office@vsbcetec.com Website : www.vsbcetec.com

24. What is the ratio of maximum shear stress to the average shear stress in the case of solid circular section?  
(APR/MAY 2019)

### PART- B (13 Marks)

1. A simply supported beam of 16 m effective span carries the concentrated loads of 4 kN, 5 kN and 3 kN at distances 3 m, 7 m and 11 m respectively from the left support. Calculate maximum shearing force and bending moment. Draw S.F. and B.M. diagrams. (APR/MAY 2018)
2. In an overhanging beam CABD of total length 12 m, the supports A and B are at a distance of 8 m from each other. Distance CA is such that the reaction at A is  $\frac{2}{3}$  of total load. The beam carries UDL of 20 kN/m over its entire length and the point load of 70 kN acts at C and the other point load of 50 kN acts at D. Determine the length of the overhanging points CA and BD and draw SFD and BMD. Find the maximum and minimum bending moment and the point of contraflexure if any.
3. (i) Find the dimensions of a timber joist, span 4 m to carry a brick wall 230 mm thick and 3 m high if the unit weight of brick work is  $20 \text{ kN/m}^3$ . Permissible bending stress in timber is  $10 \text{ N/mm}^2$ . The depth of the joist is twice the width.  
(ii) A flitched beam shown in fig. is used as a load carrying member. Find the moment of resistance of the combined section and bending stress in steel, if  $E_s = 2 \times 10^5 \text{ N/mm}^2, E_w = 1.25 \times 10^5 \text{ N/mm}^2$ .

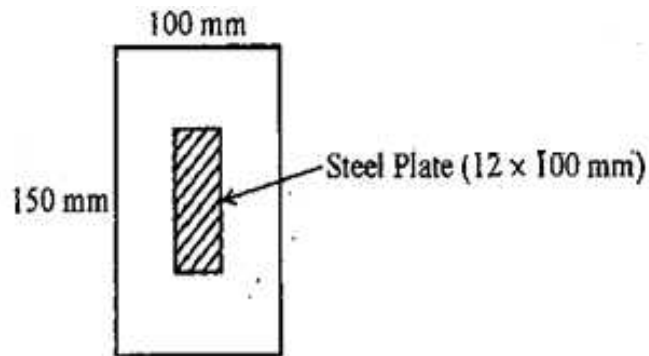

4. Three blanks of each 50 x 200 mm timber are built up to a symmetrical I section for a beam. The maximum shear force over the beam is 4KN. Propose an alternate rectangular section of the same material so that the maximum shear stress developed is same in both sections. Assume then width of the section to be  $\frac{2}{3}$  of the depth.





## VSB College of Engineering Technical Campus

Approved by AICTE, New Delhi & Affiliated to Anna University  
Coimbatore to pollachi Road NH - 209, Ealur Privu, Kinathukadavu Taluk,  
Coimbatore - 642109, Tamilnadu, India. Email: office@vsbcetc.com Website : www.vsbcetc.com

5. A beam of uniform section 10 m long carries a udl of 2KN/m for the entire length and a concentrated load of 10 KN at right end. The beam is freely supported at the left end. Find the position of the second support so that the maximum bending moment in the beam is as minimum as possible. Also compute the maximum bending moment
6. A beam of size 150 mm wide, 250 mm deep carries a uniformly distributed load of  $w$  kN/m over entire span of 4 m. A concentrated load 1 kN is acting at a distance of 1.2 m from the left support. If the bending stress at a section 1.8 m from the left support is not to exceed  $\frac{2}{3} \times 25$  N/mm<sup>2</sup> find the load  $w$ .
7. A cantilever of 2m length carries a point load of 20 KN at 0.8 m from the fixed end and another point of 5 KN at the free end. In addition, a u.d.l. of 15 KN/m is spread over the entire length of the cantilever. Draw the S.F.D, and B.M.D.
8. A Simply supported beam of effective span 6 m carries three point loads of 30 KN, 25 KN and 40 KN at 1m, 3m and 4.5m respectively from the left support. Draw the SFD and BMD. Indicating values at salient points.
9. A Simply supported beam of length 6 metres carries a udl of 20KN/m throughout its length and a point of 30 KN at 2 metres from the right support. Draw the shear force and bending moment diagram. Also find the position and magnitude of maximum Bending moment.
10. A Simply supported beam 6 metre span carries udl of 20 KN/m for left half of span and two point loads of 25 KN and 35 KN at 4 m and 5 m from left support. Find maximum SF and BM and their location drawing SF and BM diagrams.
11. A cantilever 1.5m long is loaded with a uniformly distribution load of 2 kN/m run over a length of 1.25m from the free end it also carries a point load of 3kn at a distance of 0.25m from the free end. Draw the shear force and bending moment diagram of the cantilever.



## VSB College of Engineering Technical Campus

Approved by AICTE, New Delhi & Affiliated to Anna University  
Coimbatore to pollachi Road NH - 209, Ealur Privu, Kinathukadavu Taluk,  
Coimbatore - 642109, Tamilnadu, India. Email: office@vsbcetc.com Website : www.vsbcetc.com

12. For the simply supported beam loaded as shown in Fig. , draw the shear force diagram and bending moment diagram. Also, obtain the maximum bending moment.

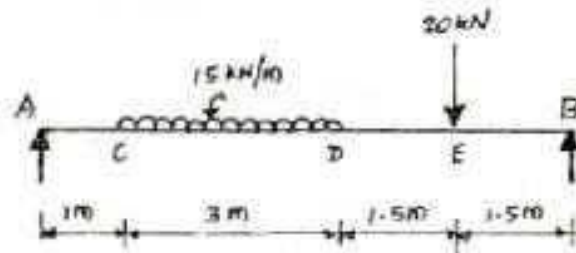

13. A cast iron beam is of T-section as shown in Fig. The beam is simply supported on a span of 6 m. The beam carries a uniformly distributed load of 2kN/m on the entire length (span). Determine the maximum tensile and maximum compressive stress.

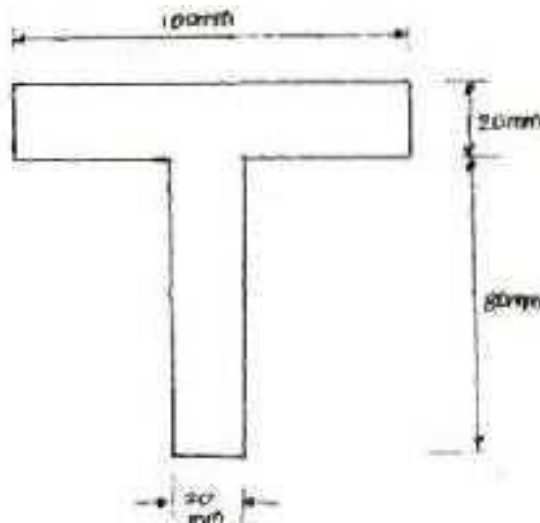



## VSB College of Engineering Technical Campus

Approved by AICTE, New Delhi & Affiliated to Anna University  
Coimbatore to pollachi Road NH - 209, Ealur Privu, Kinathukadavu Taluk,  
Coimbatore - 642109, Tamilnadu, India. Email: office@vsbcetec.com Website : www.vsbcetec.com

### UNIT III

#### TORSION

##### PART-A (2 Marks)

1. Why hollow circular shafts are preferred over solid circular shafts? (NOV/DEC 2019)
2. Write down the expression for power transmitted by a shaft. (APR/MAY 2019)
3. What is called Twisting moment?
4. What is polar moment of inertia for solid shaft? (APR/MAY 2018)
5. Differentiate open coiled helical spring from closed coiled helical spring and state the types of stress induced in each spring due to axial load. (APR/MAY 2018)
6. What is a spring? Name the two important types of spring. (NOV/DEC 2017)
7. Define Torsional rigidity. (NOV/DEC 2019)
8. The shearing stress in a solid shaft is not to exceed  $40 \text{ N/mm}^2$  when the torque transmitted is  $20000 \text{ Nm}$ . Determine the minimum diameter of the shaft.
9. What is resilience?
10. What is meant by spring constant?
11. Compute the torsional rigidity of a  $100 \text{ mm}$  diameter,  $4 \text{ m}$  length shaft  $C=80 \text{ Kn/mm}^2$
12. Define: Torsional rigidity of a shaft.
13. What do mean by strength of a shaft?
14. Write down the equation for Wahl factor.
15. Define: Torsional stiffness.
16. How will you find maximum shear stress induced in the wire of a close-coiled helical spring carrying an axial load?
17. Write the expressions for stiffness of a close coiled helical spring.
18. Find the minimum diameter of shaft required to transmit a torque of  $29820 \text{ Nm}$  if the maximum shear stress is not to exceed  $45 \text{ N/mm}^2$ .
19. Find the torque which a shaft of  $50 \text{ mm}$  diameter can transmit safely, if the allowable shear stress is  $75 \text{ N/mm}^2$ .
20. Differentiate open coiled helical spring from the close coiled helical spring and state the type of stress induced in each spring due to an axial load.
21. What is spring index (C)?
22. Define helical springs. (APR/MAY 2019)
23. State any two functions of springs.
24. Write the polar modulus for solid shaft and circular shaft.



## VSB College of Engineering Technical Campus

Approved by AICTE, New Delhi & Affiliated to Anna University  
Coimbatore to pollachi Road NH - 209, Ealur Privu, Kinathukadavu Taluk,  
Coimbatore - 642109, Tamilnadu, India. Email: office@vsbcetcc.com Website : www.vsbcetcc.com

25. What are the assumptions made in Torsion equation
26. Write an expression for the angle of twist for a hollow circular shaft with external diameter  $D$ , internal diameter  $d$ , length  $l$  and rigidity modulus  $G$ .

### PART- B (16 Marks)

1. A solid cylindrical shaft is to transmit 300 kW power at 100 rpm. a) if the shear stress not exceed  $80 \text{ N/mm}^2$ , find its diameter. b) what percentage saving in weight would be obtained if this shaft is replaced by a hollow one whose internal diameter equals to 0.6 times the external diameter, the length, material and maximum shear stress being the same. (APR/MAY 2018)
2. A closed coil helical spring is to have a stiffness of  $1.5 \text{ N/mm}$  of compression under a maximum load of 60 N. The maximum shearing stress produced in the wire of the spring is  $125 \text{ N/mm}^2$ . The solid length of the spring is 50 mm. Find the diameter of coil, diameter of wire and number of coils  $C = 4.5 \times 10^4 \text{ N/mm}^2$ . (APR/MAY 2018)
3. A hollow shaft is to transmit 300 kW power at 80 rpm. if the shear stress is not exceed  $60 \text{ N/mm}^2$  and the internal diameter is 0.6 of the external diameter, find the external and internal diameters assuming that the maximum torque is 1.4 times the mean. (NOV/DEC 2017)
4. A closely coiled helical spring made of 10 mm diameter steel wire has 15 mm coils of 100 mm mean diameter. The spring is subjected to an axial load of 100 N. Calculate : (i) The maximum shear stress induced, (ii) The deflection and (iii) Stiffness of the spring. Take modulus of rigidity =  $8.16 \times 10^4 \text{ N/mm}^2$ . (NOV/DEC 2017)
5. A solid shaft has to transmit the power 105 kW at 2000 rpm. The maximum torque transmitted in each revolution exceeds the mean by 36%. Find the suitable diameter of the shaft if the shear stress is not to exceed  $75 \text{ N/mm}^2$  and maximum angle of twist is  $1.5^\circ$  in a length of 3.30 m and  $G = 0.890 \times 10^5 \text{ N/mm}^2$ .



## VSB College of Engineering Technical Campus

Approved by AICTE, New Delhi & Affiliated to Anna University  
Coimbatore to pollachi Road NH - 209, Ealur Privu, Kinathukadavu Taluk,  
Coimbatore - 642109, Tamilnadu, India. Email: office@vsbcetec.com Website : www.vsbcetec.com

- A laminated spring carries a central load of 5200 N and it is made of 'n' number of plates, 80 mm wide, 7 mm thick and length 500 mm. Find the number of plates, if the maximum deflection is 10 mm. Let  $E = 2.0 \times 10^5$  N/mm<sup>2</sup>.
- A stepped solid circular shaft is built in at its ends and subject to an externally applied torque T at the shoulder as shown in fig. Determine the angle of rotation  $\Theta$  of the shoulder section when T is applied.

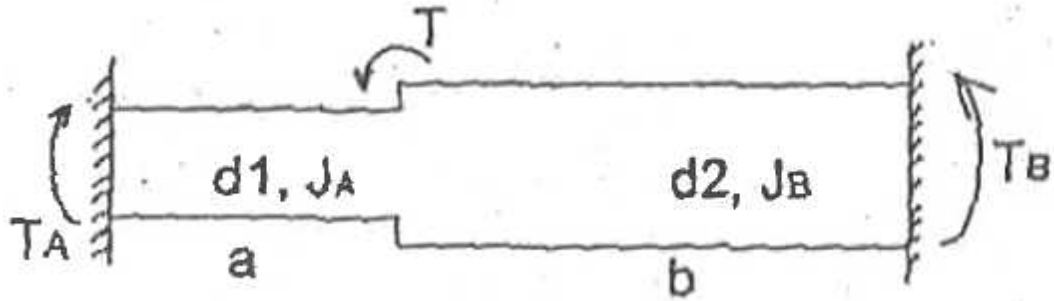

- A closed coiled helical spring is to be made out of 5 mm diameter wire 2 m long so that it deflects by 20 mm under an axial load of 50 N. determine the mean diameter of the coil. Take  $C = 8.1 \times 10^4$  N/mm<sup>2</sup>.
- A closely coiled helical spring of mean diameter 20 cm is made of 3 cm diameter rod and has 16 turns. A weight of 3 kN is dropped on this spring. Find the height by which the weight should be dropped before striking the spring so that the spring may be compressed by 18 cm. take  $C = 8 \times 10^4$  N/mm<sup>2</sup>.
- A hollow shaft having internal diameter 0.6 times external diameter is to replace a solid shaft of the same material to transmit 500 kW at 200 rpm. the permissible shear stress is 40 N/mm<sup>2</sup>. calculate the diameters of the solid and hollow shafts. Also calculate the percentage saving in material.
- A closely coiled helical spring of mean diameter 20 cm is made of 3 cm diameter rod and has 16 turns. A weight of 3 kN is dropped on this spring. Find the height by which the weight should be dropped before striking the spring so that the spring may be compressed by 18 cm. Take  $C = 8 \times 10^4$  N/mm<sup>2</sup>.



## VSB College of Engineering Technical Campus

Approved by AICTE, New Delhi & Affiliated to Anna University  
Coimbatore to pollachi Road NH - 209, Ealur Privu, Kinathukadavu Taluk,  
Coimbatore - 642109, Tamilnadu, India. Email: office@vsbcetcc.com Website : www.vsbcetcc.com

12. A hollow shaft of external diameter 120 mm transmits 300 Kw power at 200 r.p.m  
.determine the maximum internal diameter, if the maximum stress in the shaft is not to exceed  $60 \text{ N/mm}^2$ .
13. Derive a relation for deflection of a closely coiled helical spring subjected to an axial compressive load "W"
14. Figure shown a composite shaft ,if 2KN-m torque is applied at the junction between determine the maximum shear stress developed in steel and copper shaft . $C_{\text{steel}} = 2 C_{\text{COPPER}}$
15. A hollow shaft having an inside diameter 60 % of its outer diameter ,is to replace a solid shaft transmitting in the same power at the same speed .Calculate percentage saving in material ,if the material to be is also the same. Determine the diameter of a solid shaft which will transmit 300 KN at 250 rpm. The maximum shear stress should not exceed  $30 \text{ N/mm}^2$  and twist should not be more than 10 in a shaft length 2m. Take modulus of  
5  
rigidity =  $1 \times 10^5 \text{ N/mm}^2$
16. The stiffness of the closed coil helical spring at mean diameter 20 cm is made of 3 cm diameter rod and has 16 turns. A weight of 3 KN is dropped on this spring. Find the height by which the weight should be dropped before striking the spring so that the spring may be  
4  
compressed by 18 cm. Take  $C = 8 \times 10^4 \text{ N/mm}^2$  .
17. It is required to design a closed coiled helical spring which shall deflect 1mm under an axial load of 100 N at a shear stress of 90 Mpa. The spring is to be made of round wire having  
5  
shear modulus of  $0.8 \times 10^5 \text{ Mpa}$ . The mean diameter of the coil is 10 times that of the coil wire. Find the diameter and length of the wire.
18. A steel shaft ABCD having a total length of 2400 mm is contributed by three different sections as follows. The portion AB is hollow having outside and inside diameters 80 mm and 50 mm respectively, BC is solid and 80 mm diameter. CD is also solid and 70 mm diameter. If the angle of twist is same for each section, determine the length of each portion and the total angle of twist. Maximum permissible shear stress is 50 Mpa and shear modulus  
 $0.82 \times 10^5 \text{ MPa}$  .



## VSB College of Engineering Technical Campus

Approved by AICTE, New Delhi & Affiliated to Anna University  
Coimbatore to pollachi Road NH - 209, Ealur Privu, Kinathukadavu Taluk,  
Coimbatore - 642109, Tamilnadu, India. Email: office@vsbcetec.com Website : www.vsbcetec.com

19. The stiffness of close coiled helical spring is  $1.5 \text{ N/mm}$  of compression under a maximum load of  $60 \text{ N}$ . The maximum shear stress in the wire of the spring is  $125 \text{ N/mm}^2$ . The solid length of the spring (when the coils are touching) is  $50 \text{ mm}$ . Find the diameter of coil, diameter of wire and number of coils.  $C = 4.5$ .
20. Calculate the power that can be transmitted at a  $300 \text{ r.p.m.}$  by a hollow steel shaft of  $75 \text{ mm}$  external diameter and  $50 \text{ mm}$  internal diameter when the permissible shear stress for the steel is  $\text{N/mm}^2$  and the maximum torque is  $1.3$  times the mean. Compare the strength of this hollow shaft with that of a solid shaft. The same material, weight and length of both the shafts are the same.
21. A solid cylindrical shaft is to transmit  $300 \text{ kW}$  power at  $100 \text{ rpm}$ . If the shear stress is not to exceed  $60 \text{ N/mm}^2$ , find its diameter. What percent saving in weight would be obtained if this shaft is replaced by a hollow one whose internal diameter equals to  $0.6$  of the external diameter, the length, the material and maximum shear stress being the same.
22. A helical spring of circular cross-section wire  $18 \text{ mm}$  in diameter is loaded by a force of  $500 \text{ N}$ . The mean coil diameter of the spring is  $125 \text{ mm}$ . The modulus of rigidity is  $80 \text{ kN/mm}^2$ . Determine the maximum shear stress in the material of the spring. What number of coils must the spring have for its deflection to be  $6 \text{ mm}$ ?
23. A close coiled helical spring is to have a stiffness of  $1.5 \text{ N/mm}$  of compression under a maximum load of  $60 \text{ N}$ . The maximum shearing stress produced in the wire of the spring is  $125 \text{ N/mm}^2$ . The solid length of the spring is  $50 \text{ mm}$ . Find the diameter of coil, diameter of wire and number of coils.  $C = 4.5 \times 10^4 \text{ N/mm}^2$ .
24. A closely coiled helical spring of round steel wire  $10 \text{ mm}$  in diameter having  $10$  complete turns with a mean diameter of  $12 \text{ cm}$  is subjected to an axial load of  $250 \text{ N}$ . Determine the deflection of the spring II. maximum shear stress in the wire and III. stiffness of the spring and IV. frequency of vibration. Take  $C = 0.8 \times 10^5 \text{ N/mm}^2$ .





## VSB College of Engineering Technical Campus

Approved by AICTE, New Delhi & Affiliated to Anna University  
Coimbatore to pollachi Road NH - 209, Ealur Privu, Kinathukadavu Taluk,  
Coimbatore - 642109, Tamilnadu, India. Email: office@vsbcetec.com Website : www.vsbcetec.com

### UNIT IV

#### DEFLECTION OF BEAMS

##### PART-A (2 Marks)

1. Write the equation giving maximum deflection in case of a simply supported beam subjected to a point load at mid span. (Apr/May 2018)
2. State the two theorems of conjugate beam method. (Apr/May 2018)
3. Where does the maximum deflection occur in cantilever beam?
4. State the condition for the use of Macaulay's method.
5. What is the maximum deflection in a simply supported beam subjected to uniformly distributed load over the entire span?
6. What is crippling load? Give the effective length of columns when both ends hinged and when both ends fixed.
7. Find the critical load of an Euler's column having 4 m length, 50 mm x 100 mm cross section and hinged at both the ends  $E = 200 \text{ kN/mm}^2$ .
8. Calculate the maximum deflection of a simply supported beam carrying a point load of 100 kN at mid span. Span = 6 m,  $E = 20000 \text{ kN/m}^2$ .
9. A cantilever beam of length 2 m is carrying a point load of 20 kN at its free end. Calculate the slope at the free end. Assume  $EI = 12 \times 10^3 \text{ kNm}^2$ .
10. Calculate the effective length of a long column, whose actual length is 4 m when : a. Both ends are fixed b. One end fixed while the other end is free.
11. A cantilever is subjected to a point load  $W$  at the free end. What is the slope and deflection at the free end?
12. What are the methods for finding out the slope and deflection at a section?
13. Why moment area method is more useful, when compared with double integration?
14. Explain the Theorem for conjugate beam method?
15. What are the points to be worth for conjugate beam method?
16. What are the different modes of failures of a column?
17. Write down the Rankine formula for columns.
18. What is effective or equivalent length of column?
19. Define Slenderness Ratio.
20. Define the terms column and strut.
21. What are the advantages of Macaulay method over the double integration method, for finding the slope and deflections of beams?



## VSB College of Engineering Technical Campus

Approved by AICTE, New Delhi & Affiliated to Anna University  
Coimbatore to pollachi Road NH - 209, Ealur Privu, Kinathukadavu Taluk,  
Coimbatore - 642109, Tamilnadu, India. Email: office@vsbcetcc.com Website : www.vsbcetcc.com

22. State the limitations of Euler's formula

3

23. A cantilever beam of length 4 m is carrying a point load of  $2 \times 10^5$  N at its free end. Calculate

the slope at the free end. Assume  $EI = 2 \times 10^5 \text{ N/mm}^2$

### PART-B (16 Marks)

1. A cantilever 2 m long is of rectangular section 120 mm wide and 240 mm deep. It carries a uniformly distributed load of 2.5 kN per meter length for length of 1.25 meters from the fixed end and a point load of 1 kN at free end. Find the deflection at the free end. Take  $E = 10 \text{ GN/m}^2$ . (Apr/May 2018)
2. A beam AB of 8 m span is simply supported at the ends. It carries a point load of 10 kN at a distance of 1 m from the end A and a uniformly distributed load of 5 kN/m for a length of 2 m from the end B. If  $I = 10 \times 10^{-6} \text{ m}^4$ , determine: (i) Deflection at the mid-span, (ii) Maximum deflection, (iii) Slope at end A. (Apr/May 2018)
3. A cantilever beam of length 3 m is carrying a point load of 50 kN at a distance of 2 m from the fixed end. If  $I = 10^8 \text{ mm}^4$  and  $E = 2 \times 10^5 \text{ N/mm}^2$ , find (i) Slope of the free end and (ii) Deflection at free end. (NOV/DEC 2017)
4. A beam length 6 m is simply supported at its ends and carries two point loads of 48 kN and 40 kN at a distance of 1 m and 3 m respectively from the left support as shown in fig
5. Using MacAulay's method
  - (i) Deflection under each load
  - (ii) Maximum deflection and
  - (iii) The point at which maximum deflection occurs,  $E = 2 \times 10^5 \text{ N/mm}^2$  and  $I = 85 \times 10^6 \text{ N/mm}^2$

(NOV/DEC 2015)

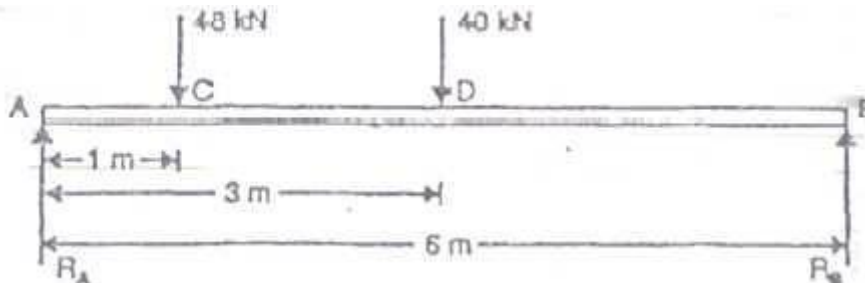



## VSB College of Engineering Technical Campus

Approved by AICTE, New Delhi & Affiliated to Anna University  
Coimbatore to pollachi Road NH - 209, Ealur Privu, Kinathukadavu Taluk,  
Coimbatore - 642109, Tamilnadu, India. Email: [office@vsbcetc.com](mailto:office@vsbcetc.com) Website : [www.vsbcetc.com](http://www.vsbcetc.com)

6. Using moment area method, drive an expression for deflection of a simply supported beam subjected beam subjected to uniformly distributed load for entire span.
7. (i) A beam is simply supported at its ends over a span of 10 m and carries a concentrated load of 100 kN at a distance of 5 m from the left support. Calculate (i) slope at the left support (ii) deflection under the 100 kN load. Assume  $EI = 36 \times 10^4 \text{ kN-m}^2$  .(7)  
(ii) Explain the moment area method for finding the deflection and slope of beams with example.
8. A simply supported beam of length 5 m carries a point load of 5 kN at a distance of 3m from the left end. If  $E = 2 \times 10^5 \text{ N/mm}^2$  and  $I = 10^8 \text{ mm}^4$ , determine the slope at the left support and deflection under the point load using conjugate beam method. (NOV/DEC 2017)
9. Derive the formula to find the deflection of a simply supported beam with point load W at the centre by moment area method.
10. A simply supported beam of span 5.80 m carries a central point load of 37.50 kN. Find the maximum slope and deflection, let  $EI = 40000 \text{ kNm}^2$ . Use conjugate beam method.
11. A cantilever of length of length 2 m carries a point load of 20 Kn at the free end and another load of 20 Kn at its centre.If  $E= 10^5 \text{ N/mm}^2$  and  $I=10^8 \text{ mm}^4$  for the cantileverthen determine by moment area method, the slope and deflection of the cantilever at the free end
12. A simply supported beam of length 4 m carries a point load of 3 KN at a distance of 1 m from each end .If  $E= 2 \times 10^5 \text{ N/mm}^2$  and  $I = 10^8 \text{ mm}^4$  for the beam ,then using conjugate beam method determine : (i) Slope at each end under each load (ii) Deflection under each load and at the centre.



## VSB College of Engineering Technical Campus

Approved by AICTE, New Delhi & Affiliated to Anna University  
Coimbatore to pollachi Road NH - 209, Ealur Privu, Kinathukadavu Taluk,  
Coimbatore - 642109, Tamilnadu, India. Email: office@vsbcetec.com Website : www.vsbcetec.com

13. A beam AB of length 8 m is simply supported at its ends and carries two point loads of 50 kN and 40 kN at a distance of 2 m and 5 m respectively from left support A. Determine, deflection under each load, maximum deflection and the position at which maximum deflection occurs. Take  $E = 2 \times 10^5 \text{ N/mm}^2$  and  $I = 8.5 \times 10^6 \text{ mm}^4$ .

14. For the cantilever beam shown in Fig.3. Find the deflection and slope at the free end.  $EI = 10000 \text{ kN/m}^2$ .

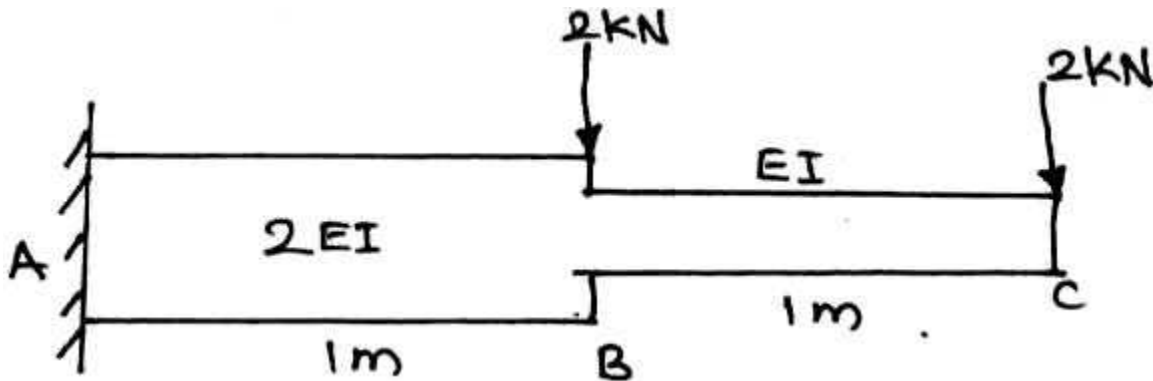

15. A beam is simply supported at its ends over a span of 10 m and carries two concentrated loads of 100 kN and 60 kN at a distance of 2 m and 5 m respectively from the left support. Calculate (i) slope at the left support (ii) slope and deflection under the 100 kN load. Assume  $EI = 36 \times 10^4 \text{ kN-m}^2$ .
16. Find the Euler critical load for a hollow cylindrical cast iron column 150 mm external diameter, 20 mm wall thickness if it is 6 m long with hinged at both ends. Assume Young's modulus of cast iron as  $80 \text{ kN/mm}^2$ . Compare this load with that given by Rankine formula. Using Rankine constants  $a = 1/1600$  and  $567 \text{ N/mm}^2$ .
17. A 3 m long cantilever of uniform rectangular cross-section 150 mm wide and 300 mm deep is loaded with a point load of 3 kN at the free end and a udl of 2 kN/m over the entire length. Find the maximum deflection.  $E = 210 \text{ kN/mm}^2$ . Use Macaulay's method.
18. A simply supported beam of span 6 m is subjected to a udl of 2 kN/m over the entire span and a point load of 3 kN at 4 m from the left support. Find the deflection under the point load in terms of EI. Use strain energy method.



## VSB College of Engineering Technical Campus

Approved by AICTE, New Delhi & Affiliated to Anna University  
Coimbatore to pollachi Road NH - 209, Ealur Privu, Kinathukadavu Taluk,  
Coimbatore - 642109, Tamilnadu, India. Email: [office@vsbcetc.com](mailto:office@vsbcetc.com) Website : [www.vsbcetc.com](http://www.vsbcetc.com)

19. A simply supported beam of uniform flexural rigidity  $EI$  and span  $l$ , carries two symmetrically placed loads  $P$  at one-third of the span from each end. Find the slope at the supports and the deflection at mid-span. Use moment area theorems.
  
20. Derive double integration method for cantilever beam concentrated load at free end.



**UNIT V**

**THIN CYLINDERS, SPHERES AND THICK CYLINDERS PART-A (2**

**Marks)**

1. Write the expression for circumferential stress and longitudinal stress when a thin cylinder is subjected to an internal fluid pressure of 'P'. (APR/MAY 2018)
2. Write down the Lamé's equations. (APR/MAY 2018)
3. Define thin cylinders. (NOV/DEC 2017)
4. List the assumptions made in Lamé's theory. (NOV/DEC 2017)
5. Name the stresses develop in the cylinder.
6. Define radial pressure in thin cylinder.
7. How does a thin cylinder fail due to internal fluid pressure? (APR/MAY 2017)
8. A cylindrical pipe of diameter 1.5 m and thickness 1.5 cm is subjected to an internal fluid pressure of  $1.2 \text{ N/mm}^2$ . Determine the longitudinal stress developed in the pipe.
9. Find the thickness of the pipe due to an internal pressure of  $10 \text{ N/mm}^2$  if the permissible stress is  $120 \text{ N/mm}^2$ . The diameter of pipe is 750 mm.
10. The principal stress at a point are  $100 \text{ N/mm}^2$  (tensile) and  $50 \text{ N/mm}^2$  (compressive) respectively. Calculate the maximum shear stress at this point.
11. A spherical shell of 1 m diameter is subjected to an internal pressure  $0.5 \text{ N/mm}^2$ . Find the thickness if the thickness of the shell, if the allowable stress in the material of the shell is  $75 \text{ N/mm}^2$ .
12. Normal stresses  $s_x$  and  $s_y$  and shear stress  $t$  act at a point. Find the principal stresses and the principal planes.
13. Derive an expression for the longitudinal stress in a thin cylinder subjected to a uniform internal fluid pressure.
14. Distinguish between thick and thin cylinders.
15. What is mean by compressive and tensile force?
16. How will you determine the forces in a member by method of joints?
17. Define thin cylinder?
18. What are types of stress in a thin cylindrical vessel subjected to internal pressure?
19. What is mean by Circumferential stress (or hoop stress) and Longitudinal stress?
20. What are the formula for finding circumferential stress and longitudinal stress?



## VSB College of Engineering Technical Campus

Approved by AICTE, New Delhi & Affiliated to Anna University  
Coimbatore to Pollachi Road NH - 209, Ealur Privu, Kinathukadavu Taluk,  
Coimbatore - 642109, Tamilnadu, India. Email: office@vsbcetec.com Website : www.vsbcetec.com

21. What are maximum shear stresses at any point in a cylinder
22. What are the formula for finding circumferential strain and longitudinal strain?
23. What are the formula for finding change in diameter, change in length and change volume of a cylindrical shell subjected to internal fluid pressure  $p$ ?
24. Distinguish between Circumferential stress (or hoop stress) and Longitudinal stress?
25. Find the thickness of the pipe due to an internal pressure of  $10 \text{ N/mm}^2$  if the permissible stress is  $120 \text{ N/mm}^2$ . The diameter of pipe is  $750 \text{ mm}$ .
26. What do you mean by a thick compound cylinder? How will you determine the hoop stresses in a thick compound cylinder?

### PART -B ( 16 MARKS)

1. A cylindrical shell 3 m long which is closed at the ends has a internal diameter of 1.5 m and a wall thickness of 20 mm. Calculate the circumferential and longitudinal stresses induced and also change in the dimensions of the steel. If it is subjected to an internal pressure of  $1.5 \text{ N/mm}^2$ . Take young's modulus =  $200 \text{ kN/mm}^2$  and poisson's ratio = 0.3. (APR/MAY 2018)
2. Calculate i) the change in diameter, ii) change in length and iii) change in volume of a thin cylindrical shell 10 cm diameter, 1 cm thick and 5 m long when subjected to internal pressure of  $3 \text{ N/mm}^2$ . Take the value of  $E = 2 \times 10^5 \text{ N/mm}^2$  and Poisson's ratio 0.3. (NOV/DEC 2017)
3. Determine the maximum and minimum hoop stress across the section of a pipe of 400 mm internal diameter and 100 mm thick, when the pipe contains a fluid at a pressure of  $8 \text{ N/mm}^2$ . Also sketch the radial pressure distribution and hoop stress distribution. (NOV/DEC 2017)
4. Calculate the thickness of metal necessary for a cylindrical shell of internal diameter 160 mm to withstand an internal pressure of  $25 \text{ MN/m}^2$ , if maximum permissible shear stress is  $125 \text{ MN/m}^2$
5. Derive the relation for change in volume of a thin cylinder subjected to internal fluid pressure. (APR/MAY 2017)





## VSB College of Engineering Technical Campus

Approved by AICTE, New Delhi & Affiliated to Anna University  
Coimbatore to pollachi Road NH - 209, Ealur Privu, Kinathukadavu Taluk,  
Coimbatore - 642109, Tamilnadu, India. Email: office@vsbcetec.com Website : www.vsbcetec.com

6. A cylindrical vessel is 2 m diameter and 5 m long is closed at ends by rigid plates. It is subjected to an internal fluid pressure of  $4 \text{ N/mm}^2$ . If the maximum principal stress is not to exceed  $210 \text{ N/mm}^2$ , find the thickness of the shell. Assume  $E = 2 \times 10^5 \text{ N/mm}^2$  and poisson's ratio = 0.3. Find the changes in diameter, length and volume of the shell. (APR/MAY 2017)
7. A thin cylinder 1.5 m internal diameter and 5 m long is subjected to an internal pressure of  $2 \text{ N/mm}^2$ . If the maximum stress is limited to  $160 \text{ N/mm}^2$ , find the thickness of the cylinder.  $E = 200 \text{ kN/mm}^2$  and Poisson's ratio = 0.3. Also find the changes in diameter, length and volume of the cylinder.
8. At a point in a strained material the horizontal tensile stress is  $80 \text{ N/mm}^2$  and the vertical compressive stress is  $140 \text{ N/mm}^2$ . The shear stress is  $40 \text{ N/mm}^2$ . Find the principal stresses and the principal planes. Find also the maximum shear stress and its planes.
9. A thin cylindrical shell 3 m long has 1m internal diameter and 15 mm metal thickness. Calculate the circumferential and longitudinal stresses induced and also the change in the dimensions of the shell, if it is subjected to an internal pressure of  $1.5 \text{ N/mm}^2$ . Take  $E = 2 \times 10^5 \text{ N/mm}^2$  and poisson's ratio = 0.3. Also calculate change in volume.
10. A closed cylindrical vessel made of steel plates 4 mm thick with plane ends, carries fluid under pressure of  $3 \text{ N/mm}^2$ . The diameter of the cylinder is 25cm and length is 75 cm. Calculate the longitudinal and hoop stresses in the cylinder wall and determine the change in diameter, length and Volume of the cylinder. Take  $E = 2.1 \times 10^5 \text{ N/mm}^2$  and  $1/m = 0.286$ .
11. A cylindrical shell 3 m long, 1 m internal diameter and 10 mm thick is subjected to an internal pressure of  $1.5 \text{ N/mm}^2$ . Calculate the changes in length, diameter and volume of the cylinder.  $E = 200 \text{ kN/mm}^2$ , Poisson's ratio = 0.3.



## VSB College of Engineering Technical Campus

Approved by AICTE, New Delhi & Affiliated to Anna University  
Coimbatore to pollachi Road NH - 209, Ealur Privu, Kinathukadavu Taluk,  
Coimbatore - 642109, Tamilnadu, India. Email: office@vsbcetec.com Website : www.vsbcetec.com

12. A steel cylindrical shell 3 m long which is closed at its ends, had an internal diameter of 1.5 m and a wall thickness of 20 mm. Calculate the circumferential and longitudinal stress induced and also the change in dimensions of the shell if it is subjected to an internal pressure of  $1.0 \text{ N/mm}^2$ . Assume the modulus of elasticity and Poisson's ratio for steel as  $200 \text{ kN/mm}^2$  and 0.3 respectively.
13. A cylindrical shell 3 m long which is closed at the ends has an internal diameter 1m and wall thickness of 15 mm. Calculate the change in dimensions and change in volume if the internal pressure is  $1.5 \text{ N/mm}^2$ ,  $E = 2 \times 10^5 \text{ N/mm}^2$ ,  $\mu = 0.3$ .
14. A cylindrical shell 3 m long which is closed at the ends, has an internal diameter of 1m and a wall thickness of 20 mm. Calculate the circumferential and longitudinal stresses induced and also changes in the dimensions of the shell, if it is subjected to an internal pressure of  $2.0 \text{ N/mm}^2$ . Take  $E = 2 \times 10^5 \text{ N/mm}^2$  and  $\mu = 0.3$ .
15. A closed cylindrical vessel made of steel plates 5 mm thick with plane ends, carries fluid under pressure of  $6 \text{ N/mm}^2$ . The diameter of the cylinder is 35cm and length is 85 cm. Calculate the longitudinal and hoop stresses in the cylinder wall and determine the change in diameter, length and Volume of the cylinder. Take  $E = 2.1 \times 10^5 \text{ N/mm}^2$  and  $\mu = 0.286$ .
16. Determine the maximum hoop stress across the section of a pipe of external diameter 600mm and internal diameter 440mm. when the pipe is subjected to an internal fluid pressure of  $50 \text{ N/mm}^2$ .



# VSB College of Engineering Technical Campus

Approved by AICTE, New Delhi & Affiliated to Anna University  
Coimbatore to pollachi Road NH - 209, Ealur Privu, Kinathukadavu Taluk,  
Coimbatore - 642109, Tamilnadu, India. Email: office@vsbcetc.com Website : www.vsbcetc.com

## VSB ENGINEERING COLLEGE, KARUR.

### DEPARTMENT OF MECHANICAL ENGINEERING QUESTION BANK

#### ME8451 - MANUFACTURING TECHNOLOGY – II UNIT I -

#### THEORY OF METAL CUTTING

##### PART A

1. List the various metal removal processes?
2. How chip formation occurs in metal cutting?
3. What is tool wear?
4. Mention the cutting fluids?
5. Draw the nomenclature of cutting tool geometry?
6. Compare orthogonal and oblique cutting?
7. Define tool life.
8. What are the objectives and functions of cutting fluids?
9. Briefly explain the effect of rake angle during cutting?
10. What are the factors responsible for built-up edge in cutting tools?
11. List out the essential characteristics of a cutting fluid.
12. Name the various cutting tool materials.
13. Give two examples of orthogonal cutting.
14. What are the four important characteristics of materials used for cutting tools?
15. What is the function of chip breakers?
16. Name the factors that contribute to poor surface finish in cutting.
17. Express the Taylor's tool life equation.
18. What are all the factors considered for selection of cutting speed?
19. What is chip thickness ratio?
20. What are the assumptions made by merchant circle?

##### PART B

1. a. Explain the classification of various cutting tool materials? b. State the properties of each of the tool materials.
2. a. The Taylor tool life equation for machining C-40 steel with a HSS cutting tool at a feed of 0.2mm/min and a depth of cut of 2mm is given by  $VT^n = C$ , Where n and C are constants. The following V and T observations have been noted

V, m/min	25	35
T, min	90	20

Calculate

(1) n and C

(2) Hence recommend the cutting speed for a desired tool life of 60min.

b. In an orthogonal cutting operation on a work piece of width 2.5mm, the uncut chip thickness was 0.25mm and the tool rake angle was zero degree. It was observed that the chip thickness was 1.25mm. The cutting force was measured to be 900N and the thrust force was found to be 810 N

(b) Find the shear angle.

(c) If the coefficient of friction between the chip and the tool, was 0.5, what is the machining constant  $C_m$



## VSB College of Engineering Technical Campus

Approved by AICTE, New Delhi & Affiliated to Anna University  
Coimbatore to pollachi Road NH - 209, Ealur Privu, Kinathukadavu Taluk,  
Coimbatore - 642109, Tamilnadu, India. Email: office@vsbcetec.com Website : www.vsbcetec.com

3. What is a chip breaker? Describe the different types of chips produced during metal machining with neat sketches.
4. With the help of a sketch, show crater wear and flank wear on a cutting tool.
5. a. What is machinability? And explain.  
b. Mention the functions and properties of cutting fluids
6. Describe an expression for the determination of shear angle in Orthogonal metal cutting.
7. a. Describe the mechanism of metal cutting?  
b. What is meant by orthogonal cutting and oblique cutting?
8. Explain "merchant force circle" along with assumptions.
9. What are the standard angles of cutting tool? Illustrate with an example.
10. a. State the parameters that influence the life of tool and discuss?  
b. Explain the geometry of a single point cutting tool with suitable sketches?

### UNIT II - TURNING MACHINESPART

#### A

1. What are the various operations can be performed on a lathe?
2. What are the principle parts of a lathe?
3. What is the main requites of a lathe bed?
4. What are the uses of headstock?
5. What is the main difference between live center and dead center?
6. State the various parts mounted on the carriage.
7. What is a compound rest?
8. List any four types of lathes?
9. What is a semi-automatic lathe? What are the advantages semi-automatic lathes?
10. State the various methods for taper turning operation.
11. Define feed. State the various feed mechanisms used for obtaining automatic feed.
12. List any four work holding devices.
13. Mention the use of chucks.
14. What are the various types of chucks?
15. Define filing operation.
16. Define the process "grooving".
17. What is reaming and boring operation?
18. Define the term "Conicity".
19. Write down the formula for calculating taper turning angle by compound rest method.
20. What are the functions of feed rod and lead screw?

#### PART B

1. Explain the various taper turning methods?
2. a. Discuss about special attachments of lathe.  
b. Mention the specifications of lathe with a neat sketch.
3. a. Describe the turret indexing mechanism.  
b. Discuss about the bar feed mechanism.
4. a. Describe the holding devices in a lathe.  
b. Explain the working principle of apron mechanism with neat sketch.
5. Draw neat sketches of steady and follower rests and brief their applications.
6. Describe the constructional features of Swiss type automatic screw machine.
7. Explain the working principle of a capstan and turret lathe.



## VSB College of Engineering Technical Campus

Approved by AICTE, New Delhi & Affiliated to Anna University  
Coimbatore to pollachi Road NH - 209, Ealur Privu, Kinathukadavu Taluk,  
Coimbatore - 642109, Tamilnadu, India. Email: office@vsbcetec.com Website : www.vsbcetec.com

8. Name the various lathe accessories. How does a four jaw chuck differ from a three jaw chuck?
9. Explain the features and classification of multi spindle automatics.
10. a. Discuss the features of ram type and saddle type Turret.  
b. What is meant by "Tool layout" of a Turret lathe?

### **UNIT III - SHAPER, MILLING AND GEAR CUTTING MACHINESPART A**

1. Mention the differences between shaper and planer.
2. What are the differences between drilling and reaming?
3. What are the differences between drilling and reaming?
4. Briefly describe the importance of quill mechanism.
5. List the types of sawing machines.
6. Define the cutting speed, feed and machining time for drilling.
7. What is broaching.
8. What is the difference between up milling and down milling?
9. List four applications of broaching machines.
10. How do you classify milling cutters?
11. What do you know about straight fluted drill and fluted drill?
12. What is meant by up milling and down milling?
13. State the differences between a vertical shaper and slotters.
14. Write the differences between drilling and tapping.
15. What is a shell mill?
16. Mention the operations performed by a planner.
17. Why is sawing a commonly used process.
18. What is vertical milling machine?
19. What are the different operations performed in drilling machine?
20. How are the non-ferrous metals held in magnetic chuck?

### **PART-B**

1. a. Explain various milling cutters with neat sketches?  
b. How will you cut the following types of surfaces on milling machines?  
(i) Flat surfaces                      (ii) Slots and splines
2. Discuss various hole making processes.
3. With a neat sketch explain the column and knee type milling machine and name its main parts.
4. a. Explain hacksaw and band saw with neat sketches.  
b. Explain the different types of table drive and feed mechanisms in a planning machine .
5. a. Discuss push and pull type broaching machines with neat sketches.  
b. Write short notes on expanding hand reamers and adjustable machine reamers.  
6. a. Sketch and explain the hydraulic drive of a horizontal shaper.  
b. Describe the working of a crank and slotted link mechanism.
7. a. Discuss the principle of operation of a shaper with a neat sketch.  
b. Make a note on different types of work holding devices used in a slotting machine.
8. a. What are the operations performed on a drilling machine?
9. b. Explain different types of drilling machines with their special features?
10. a. Listout the differences between shaper and planner.  
b. Explain with a sketch "Fast and loose pulleys" quick return mechanism of a planer table.



## VSB College of Engineering Technical Campus

Approved by AICTE, New Delhi & Affiliated to Anna University  
Coimbatore to pollachi Road NH - 209, Ealur Privu, Kinathukadavu Taluk,  
Coimbatore - 642109, Tamilnadu, India. Email: office@vsbcetcc.com Website : www.vsbcetcc.com

### UNIT IV - ABRASIVE PROCESS AND BROACHING PART A

1. What are the specifications of grinding wheel?
2. What is honing?
3. Narrate the working principle of abrasive jet machining.
4. What is gear hobbing?
5. Define hardness of the grinding wheel.
6. Define lapping.
7. What is meant by “grade” and “structure” of a grinding wheel?
8. What are all the parameters that would affect the MRR in abrasive jet machining?
9. Mention four important factors that influence the selection of grinding wheel.
10. What is roller burnishing process?
11. What is the need of truing and dressing operations in a grinding wheel?
12. List the advantages of honing?
13. State the abrasives used in manufacture of grinding wheels.
14. What are the different types of external grinders?
15. What are the operations done in centre less grinders?
16. What are the work holding and supporting devices used in grinders?
17. Why the centre less grinders is called specialized machine for cylindrical parts?
18. What are the different types of fine finishing process?
19. What are the various methods of shaping the gear blank?
20. What is broaching?

### **PART- B**

1. Explain the working mechanism of cylindrical and surface grinding.
2. a. Describe gear cutting by forming and shaping.  
b. Give the specification of grinding wheel.
3. Explain the working principle and various methods of centreless grinding with a neat sketch.
4. Sketch and explain the three methods of external cylindrical centreless grinding.
5. What is meant dressing and truing of grinding wheel?
6. Explain the abrasive jet grinding with diagram.
7. How do you classify cylindrical grinders? What is the difference between “Plain and universal “cylindrical grinder?
8. a. Write short notes on gear shaping.  
b. List the advantages and disadvantages of gear shaping process.
9. a. Describe Honing process.  
b. Explain gear hobbing process over other gear generation processes.
10. a. Briefly discuss about the different types of abrasives used in a grinding wheel.  
b. Describe the use of cutting fluids in grinding.



## VSB College of Engineering Technical Campus

Approved by AICTE, New Delhi & Affiliated to Anna University  
Coimbatore to pollachi Road NH - 209, Ealur Privu, Kinathukadavu Taluk,  
Coimbatore - 642109, Tamilnadu, India. Email: office@vsbcetc.com Website : www.vsbcetc.com

### UNIT - V CNC MACHINING PART - A

1. List the differences between NC and CNC.
2. What are linear bearings?
3. Mention the type of ball screws.
4. What are feed drives?
5. What are the types of motion control system used in NC machines?
6. What is meant by APT language?
7. Compare a closed loop NC system with open loop system.
8. What is a preparatory function? How is it important in CNC programming?
9. State the limitations of CNC machine tools.
10. What is a canned cycle?
11. Define NC. Name the major elements of NC machines.
12. What are the classifications of NC machines?
13. What is the difference between incremental and absolute system.
14. What is the role of computer for NC machine tool?
15. What is point –to – point (PTP) system?
16. What are G-Codes and M-Codes? Give examples.
17. List the commonly used coordinate systems of CNC machine tools.
18. Write down the types of statements in APT language.
19. Write the various types of tape readers.
20. Write the disadvantages of manual part programming.

### PART -B

1. Define CNC and DNC. With a help of a diagram explain the working of NC machine tool.
2. a. Narrate the design considerations of CNC machines.  
b. Discuss about slide ways used in CNC machine tools.
3. a. List the difference between manual and computer assisted part programming.  
b. Describe the drive systems used in CNC.
4. Explain the following in CNC machining.
  - a. Linear Interpolation
  - b. Circular Interpolation
  - c. Cubic interpolation
5. a. Explain the main difference between point to point and continuous path of numerically controlled machinetools.  
b. Under what conditions of production the numerically controlled machine tools are employed.
6. a. With a neat sketch, explain the working of ATC?  
b. Write short notes on APT language.
7. Explain the various elements of NC machine with closed loop control system.
8. Describe the spindle and feed drives. State the requirement of the drives of CNC machine tools.
9. a. List any five motions and control statements of computer assisted NC programming and explain.  
b. Under what conditions of production the numerically controlled machine tools are employed.





# VSB College of Engineering Technical Campus

Approved by AICTE, New Delhi & Affiliated to Anna University  
Coimbatore to pollachi Road NH - 209, Eatur Privu, Kinathukadavu Taluk,  
Coimbatore - 642109, Tamilnadu, India. Email: office@vsbcetec.com Website : www.vsbcetec.com

10. a. Write the part program for the part shown below.

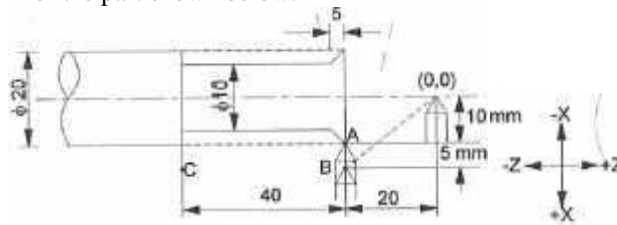

b. Write the part program for drilling holes in the part shown below. The plate thickness is 20mm.

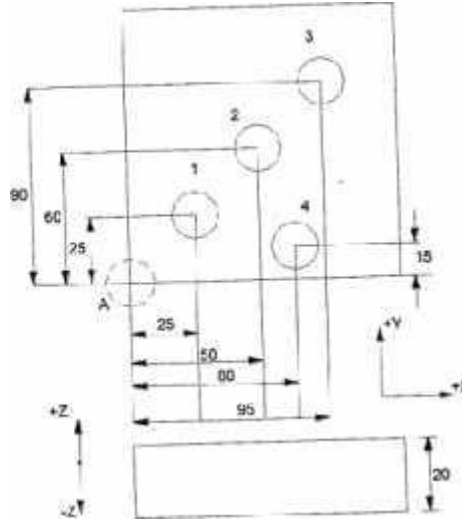



**ME8493 THERMAL ENGINEERING-I**

**2Marks**

**UNIT I - GAS AND STEAM POWER CYCLES**

**1. What is a thermodynamic cycle?**

Thermodynamic cycle is defined as the series of processes performed on the system, so that the system attains its original state.

**2. What are the assumptions made for air standard cycle analysis? (April 2019)** (i) The working medium is a perfect gas throughout. It follows the law  $pV = mRT$  (ii) The working medium does not undergo any chemical change throughout the

Cycle.

(iii) The compression and expansion processes are reversible adiabatic i.e., there is no loss or gain of entropy.

(iv) The operation of the engine is frictionless.

**3. Mention the various processes of dual cycle.**

(i) Isentropic compression.

(ii) Constant pressure heat supplied.

(iii) Isentropic expansion, and

(iv) Constant pressure heat rejection.

**4. Define air standard cycle efficiency. (Nov/Dec 2018)**

Air standard efficiency is defined as the ratio of work done by the cycle to the heat supplied to the cycle.

**5. Define mean effective pressure as applied to gas power cycles. (April 2019)** Mean effective pressure is defined as the constant pressure acting on the piston during the working stroke. It is also defined as the ratio of work done to the stroke volume or piston displacement volume.

**6. Define the following terms (i) Compression ratio (ii) Cut off ratio and (iii) Expansion ratio? (Nov 2018)**

(i) Compression ratio is defined as the ratio between total cylinder volume to clearance volume.

(ii) Cut off ratio is defined as the ratio of volume after the heat addition to volume before the heat addition.

(iii) Expansion ratio is the ratio of volume after the expansion to the volume before expansion.

**7. Which cycle is more efficient with respect to the same compression ratio?**

For the same compression ratio, Otto cycle is more efficient than diesel cycle.

**8. For the same compression ratio and heat supplied, state the order of decreasing air standard efficiency of Otto, diesel and dual cycle.**

$$\eta_{\text{Otto}} > \eta_{\text{Dual}} > \eta_{\text{Diesel}}$$



**9. Name the factors that affect air standard efficiency of Diesel cycle.**

Compression ratio and cut-off ratio.

**10. What is the effect cut-off ratio on the efficiency of diesel cycle when the compression ratio is kept constant?**

When cut-off ratio of diesel cycle increases, the efficiency of cycle is decreased when compression ratio is kept constant and vice versa.

**11. Write any four major differences between Otto and diesel cycle. (Nov 2016)**

Sl.No.	Otto cycle	Diesel cycle
1	It consists of two isentropic and two constant volume processes.	It consists of two isentropic, one constant volume and one constant pressure processes.
2	Heat addition takes place of constant volume.	Heat addition takes place of constant pressure.
3	Compression ratio is equal to expansion ratio.	Compression ratio is greater than expansion ratio.
4	Efficiency is more than diesel cycle for the same compression ratio and heat input.	Efficiency is less.

**12. Name the various gas power cycles.**

1. Carnot cycle
2. Otto cycle
3. Diesel cycle
4. Brayton cycle
5. Atkinson cycle.

**13. Mention the four thermodynamic processes involved in diesel cycle.**

One reversible adiabatic compression  
One constant pressure processes  
One reversible adiabatic expansion  
One constant volume.

**14. Mention the various processes of dual cycle**

Isentropic compression  
Constant volume heat addition  
Constant pressure heat addition  
Isentropic expansion  
Constant volume heat rejection



15. Mention the various processes of the Brayton cycle.

- Isentropic compression
- Constant pressure heat supplied
- Isentropic expansion
- Constant pressure heat rejection

16. What is the effect of cut-off ratio on the efficiency of diesel cycle when the compression ratio is kept constant?

the

When the cut-off ratio of diesel cycle increases the efficiency of cycle is decreased when the compression ratio is kept constant and vice versa.

17. What are all modifications carried out in Brayton cycle? Why?

In Brayton cycle the following devices can be incorporated to increase its thermal efficiency such as (i) regenerator, (ii) reheater (iii) intercooler.

18. In case of regenerative cycle, what are the factors affecting thermal efficiency of the cycle?

Maximum cycle temperature and pressure ratio.

19. What are the effects of providing the intercooler in the gas turbine cycle?

- Heat supply is increased
- It decreases the thermal efficiency
- Work ratio will be increased.

20. Draw the diesel cycle on P-v and T-s diagrams and mark the various processes. (Nov 2019)

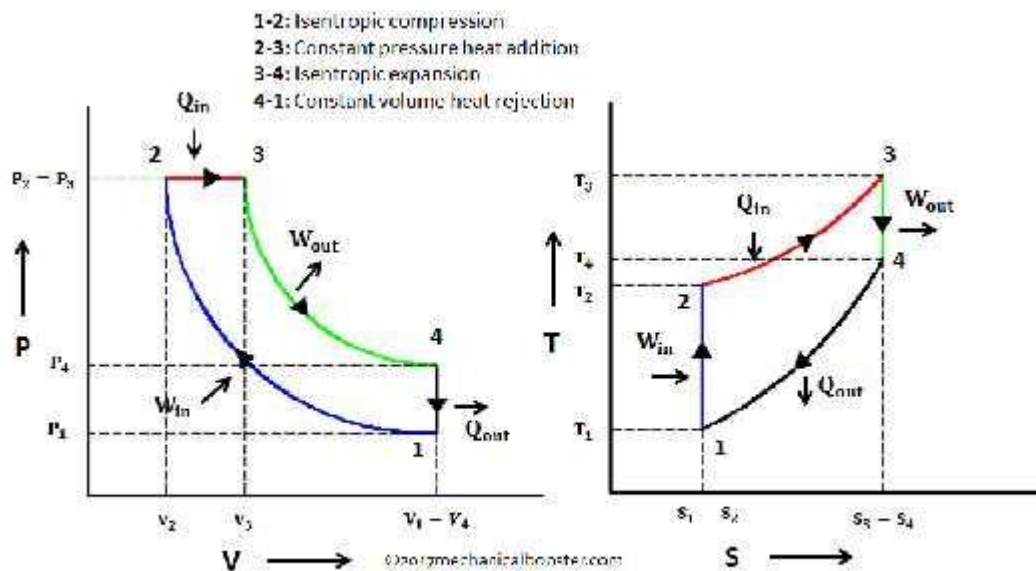

**P-V and T-S Diagram of Diesel Cycle**



**21. Why does diesel cycle have high efficiency compared to Otto cycle? (April 2019)**

Otto cycle is more efficient than Diesel cycle for a given compression ratio. For constant maximum pressure and heat input, the standard efficiency of gas power cycle is in the order.

**UNIT II – RECIPROCATING AIR COMPRESSOR**

**(1) Classify the various types of air compressors.**

1. According to the principle of operation
  - a) Reciprocating compressors
  - b) Rotary compressors.
- 2) According to the action
  - a) Single acting compressors
  - b) Double acting compressors
- 3) According to the number of stages
  - a) Single stage compressors
  - b) Multistage compressors
- 4) According to the pressure limit
  - a) Low pressure compressors
  - b) Medium pressure compressors
  - c) High pressure compressors
- 5) According to the capacity
  - a) Low capacity compressors
  - b) Medium capacity compressors
  - c) High capacity compressors

**(2) What is meant by single acting compressors?**

In single acting reciprocating compressor, the suction, compression and delivery of air takes place on both sides of the piston.

**(3) What is meant by single stage compressor?**

In single stage compressor, the compression of air from the initial pressure to the final pressure is carried out in one cylinder only.

**(4) What is meant by double acting compressor?**

In double acting reciprocating compressor, the suction, compression and delivery of air takes place on both sides of the piston.

**(5) Indicate the application of reciprocating compressors in industry? The applications of compressed air as follows:**

- 1) Pneumatic brakes
- 2) Pneumatic jacks.
- 3) Pneumatic drills.
- 4) Pneumatic lifts.
- 5) Spray painting.
- 6) Shop cleaning.
- 7) Injecting fuel in diesel engines.



**(6) What are the advantages of multi stage compression with internal cooling over single stage compression for the same pressure ratio?**

1. It improves the volumetric efficiency for the given pressure ratio.
2. It reduces the leakage loss considerably.
3. It gives more uniform torque and hence a smaller size flywheel is required.
4. It reduces the cost of the compressor.

**(7) Define the terms as applied to air compressors: Volumetric efficiency and isothermal compression efficiency.**

(or)

**Define the mechanical efficiency and isothermal efficiency of a reciprocating air compressor.**

**Volumetric efficiency:**

Volumetric efficiency is defined as the ratio of volume of free air sucked into the compressor per cycle to the stroke volume of the cylinder.

Volumetric efficiency:  $\text{Volume of free air taken per cycle} / \text{Stroke volume of the cylinder}$ .

**Isothermal compression efficiency: (April 2019)**

Isothermal efficiency is defined as the ratio between isothermal work to the actual work of the compressor.

$$\text{Isothermal efficiency} = \frac{\text{brake power}}{\text{Indicated power}}$$

**(8) Define clearance ratio?**

Clearance ratio is defined as the ratio of clearance volume to swept volume (or) stroke volume.

$$C = \frac{V_c}{V_s - V_c} = \frac{\text{Clearance}}{\text{Swept volume}}$$

$$V_s = \text{Swept volume}$$

**(9) Discuss the effect of clearance upon the performance of an air compressor.**

The volumetric efficiency of air compressor increases with decrease in clearance of the compressor.

**(10) Give two merits of rotary compressor over reciprocating compressor.**

1. Rotary compressor gives uniform delivery of air when compared to reciprocating compressor.
2. Rotary compressors are small in size for the same discharge as compared with reciprocating compressors.
3. Lubricating system is more complicated in reciprocating compressor where as it is very simple in rotary compressor.

**(11) Name the methods adopted for increasing isothermal efficiency of reciprocating air compressor.**

Isothermal efficiency is increased by perfect inter cooling.



**(12) Why clearance is necessary and what is its effect on the performance of reciprocating compressor?**

When the piston reaches top dead center in the cylinder, there is a dead space between piston top and cylinder head. This space is known as clearance space and the volume occupied by this space is known as clearance volume.

**(13) What is meant by inter cooler?**

An inter cooler is a simple heat exchanger. It exchanges the heat of compressed air from the low-pressure compressor to the circulating.

**(14) What are the factors that affect the volumetric efficiency of a reciprocating compressor?**

1. Clearance volume.
2. Compression ratio.

**(15) What is compression ratio?**

Compression ratio is defined as the ratio between total volume and clearance volume.

$$\text{Compression ratio} = \frac{\text{Total volume.}}{\text{Clearance volume.}}$$

**16. What is the advantage of multi stage compression? (Nov 2019)**

This makes compressor lighter and cheaper.

- 1) Heat removal during condensation is reduced hence size of condenser is reduced.
- 2) Volumetric efficiency of compressor increases due to reduced pressure ratio in each stage.
- 3) Temperature at end of compression would be less.

**17. How is work saving possible in multi stage compressor? (April 2019)**

When air is compressed, its temperature increases. Compressing in multiple stages allows cooling to occur between the stages, which saves work in the compression process. This brings the compression process closer to isothermal (constant temperature) compression, which is more efficient.

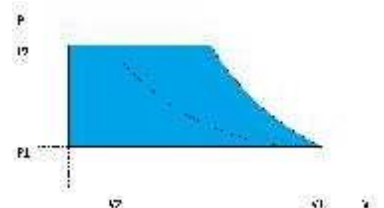





**18. What is rotary compressor? How are rotary compressors classified? (Nov 2019)**

Instead, these compressors have screws, vanes, scrolls, and other devices which rotate and thus compress air. The rotary compressors are classified into screw type, vane type-lobe type, scroll type and other types. The screw compressors are efficient in low air pressure requirements.

**UNIT III –INTERNAL COMBUSTION ENGINES AND COMBUSTION**

**1. List the various components of engine.**

- (i)Cylinder block
- (ii)Cylinder head
- (iii)Crankcase
- (iv) Cylinder liner
- (v) Piston& piston rings

**2. Name the basic thermodynamic cycles of the two types of internal combustionreciprocating engines.**

Otto cycle in S.I engines and diesel cycle in C.I engines.

**3. Define compression ratio of an IC engine?**

It is the ratio of volume when the piston is at BDC to the volume when the piston is atTDC.

**4. Define the terms Mean effective pressure?**

It is defined as the algebraic sum of the mean pressure acting on the during one completecycle.

**5. What is meant by highest useful compression ratio?**

The compression ratio which gives maximum efficiency is known as highest usefulcompression ratio.

**6. Why compression ratio of petrol engines is low while diesel engines have highcompression ratio?**

Since fire point of petrol is less as compared to diesel, petrol engine has lowcompression ratio.

**7. Compare the thermal efficiency of petrol engines with diesel engines. Give reasons.**

Thermal efficiency of diesel engine is greater than petrol engine this is due to highcompression ratio.



**8. What do you mean by scavenging in I.C. Engines?**

The process of removing the burnt gases from the combustion chamber of engine cylinder by using fresh air fuel mixture is known as Scavenging.

**9. Define Cetane number?**

The property that quantifies the ignition delay is called as Cetane number.

**10. Which is better efficient two stroke or four stroke engines?**

Two-stroke engine give always lesser efficiency than four-stroke engine due to incomplete combustion and poor scavenging.

**11. Why a choke is used in carburetor and what is meant by automatic chocking?**

Initially, more fuel is required to reduce high starting torque which is done by using supply unit will be cut off by a choke called automatic chocking.

**12. What are the important requirements of fuel injection system?**

- \* The beginning as well as end of injection should take place sharply
- \* Inject the fuel at correct time in the cycle throughout the speed range of the engine.
- \* The injection of fuel should occur at the correct rate and in correct quantity as required by the varying engine load.
- \* Atomize the fuel to the required degree.
- \* Distribute the fuel throughout the combustion chamber for better mixing.

**13. Mention different types of fuel injection systems in C. I engines.**

- a) Air injection system
- b) Airless or Solid injection
  - (i) Common rail system
  - (ii) Individual pump system.

**14. Define delay period with respect to a CI engine.**

The physical delay period is the time between the beginning of injection and the attainment of chemical reaction conditions. During this period fuel is atomized, mixed with air and raised to its self-ignition temperature.

During the chemical delay reactions start slowly and then accelerate until ignition takes place.

**15. What is the purpose of providing spark plug in SI engine?**

The function of a spark plug is to produce an electric spark for the ignition of compressed air-fuel mixture inside the engine cylinder.



**16. How cam shaft speed related to crank shaft speed? And why?(April 2019)**

The camshaft is either chain or gear driven from the crankshaft. Because the engine is a four stroke, the camshaft will rotate at half the speed of the crankshaft. (The valves and fuel pump will only operate once for every two revolutions of the crankshaft)

If the cam matched engine speed, then the intake valve would open twice in the cycle as would the exhaust valve. Any slower than half speed and you wouldn't get air in or out of the engine.

**17. What are the effect of rich mixture in petrol engine? (April 2019)**

Excessively rich and excessively lean mixtures both decrease temperatures and combustion speed. Excess fuel, as in rich mixture, cools the engine somewhat, but the effect of unburned fuel as a coolant is generally overrated. The cooling is mainly due to other effects, like lower combustion speed.

**18. How are SI and CI engine fuels rated? (Nov 2019)SI Engine**

- Anti-knocking is one of the major characteristics for the Spark-Ignition Engine Fuel.
- The resistance to the knocking is completely depended on the chemical composition of the fuel.
- Apart from this, there are other parameters which result in knocking in the spark-ignition engine, those are the air-fuel ratio, ignition timing, engine speed, dilution, the shape of the combustion chamber, compression ratio, ambient conditions.
- So before we rate the anti-knock characteristics of the fuel we have to fix those parameters to the standard values.

**CI Engine**

- In the Compression Ignition engines, the antiknock characteristics will depend on the chemical composition and also on the design and operating conditions of the engine.
- The knock rating is done by comparing the fuel under prescribed conditions of operations in a special engine with the reference fuels.

**19. What is meant by ignition delay? (Nov 2019)**

The ignition delay in a diesel engine is defined as the time interval between the start of injection and the start of combustion. This delay period consists of (a) physical delay, wherein atomization, vaporization and mixing of air fuel occur and (b) of chemical delay attributed to pre-combustion reactions



## UNIT IV –INTERNAL COMBUSTION ENGINE PERFORMANCE AND SYSTEMS

### 1. Define the following terms (a) clearance volume and (b) swept volume

**(i)** Clearance volume

The volume of the cylinder when the piston is at TDC is known as clearance volume.

**(ii)** Swept volume

It is the volume generated by the working piston when it is travelling from one dead centre to next one. It is the product of piston area and stroke

### 2. List the various parameters involved in engine performance

1. Brake power
2. Indicated power
3. Friction power
4. Total fuel consumption
5. Specific fuel consumption
6. Thermal efficiency
7. Mechanical efficiency
8. Mean effective pressure

### 3. Define the term brake power

Brake power is the useful power available at the crankshaft. It is always lesser than the indicated power. The brake power of an IC engine is usually measured by means of brake mechanism.

### 4. Define the term indicated brake power

Indicated power is defined as the power actually developed by the engine in the engine cylinder.

### 5. Define SFC in engine performance

SFC means Specific Fuel Consumption which is defined as the fuel consumed by the engine in kg for producing 1 kW-h of power.

### 6. Define TFC in engine performance.

TFC means Total Fuel Consumption which is defined as the fuel consumed by the engine in kg for 1h of operation.



**7. What do you understand by mono point injection system?**

In mono point system an injection valve is positioned slightly above each throat of the throttle body. The injection valve sprays fuel into the air just before it passes through the throttle valve and it enters the intake manifold.

**8. What do you understand by multipoint injection system?**

In multi point injection system there is an injection valve for each engine cylinder. The main advantage of this system is, it allows more time for mixing of air and petrol.

**9. What is gasoline injection system?**

If the fuel is injected directly into the combustion chamber instead of the intake port, the injection system is said to be gasoline injection system.

**10. Define continuous injection of petrol engine.**

The injection system which provides a continuous spray of fuel from each injection at a point before the intake valve is known as continuous injection system.

**11. What are the classification of an ignition system?**

1. Coil ignition system
2. Magneto ignition system
3. Electronic ignition system
4. Transistorized ignition system.

**12. Name the components of battery coil ignition system used in vehicles.**

1. Distributor
2. Contact breaker
3. Primary winding
4. Secondary winding

**13. Give the requirements of air fuel ratio in SI engine.**

SI engine automobiles run with the help of a mixture of gasoline and air. The amount of mixture depends on (i) engine displacement (ii) maximum revolution per minute

**14. What are the types of electronic ignition systems used in SI engine?**

- (i) Transistor coil ignition
- (ii) Capacitor discharge ignition



**15. State the advantages of transistorized ignition system.**

1. It increases the life of contact breaker points.
2. It gives higher ignition voltage.
3. It gives longer duration of spark.
4. It has very accurate control of timing.

**16. What is meant by lubrication?**

The process of reducing the friction between moving parts is known lubrication.

**17. What are the function of lubrication? (April 2019)**

1. It reduces friction between moving parts
2. It reduces wear and tear of the moving parts
3. It minimizes power loss due to friction
4. It provides cooling effect.

**18. What are the various methods of lubrication?**

1. Petrol lubrication
2. Wet sump system
3. Dry sump system

**19. What is the use of Morse Test? (April 2019)**

The purpose of Morse Test is to obtain the approximate Indicated Power of a Multi-cylinder Engine. When one cylinder is cut off, power developed is reduced and speed of engine falls. Accordingly, the load on the dynamometer is adjusted so as to restore the engine speed

**20. What is the necessity of cooling of an ic engine? (Nov 2019)**

The cooling system is provided in the IC engine for the following reasons: The temperature of the burning gases in the engine cylinder reaches up to 1500 to 2000°C, which is above the melting point of the material of the cylinder body and head of the engine.

**21. What is turbo charger? (Nov 2019)**

Turbine-driven forced induction device that increases an internal combustion engines efficiency and power output by forcing extra compressed air into the combustion chamber. Twin charger refers to an engine with both a supercharger and a turbocharger.



**UNIT V –GAS TURBINES**

**1. How gas turbine units are classified? ( Nov 2019)**

1. According to the cycle of operation
  - (a) Open cycle gas turbine.
  - (b) Closed cycle gas turbine
  - (c) Semi closed cycle gas turbine
2. According to the process
  - (a) Constant pressure gas turbine
  - (b) Constant volume gas turbine
3. According to the use (a) industrial gas turbine (b) air craft gas turbine.

**2. What are the main units in a gas turbine power plant?**

- (a) Compressor. (b) Combustion chamber. (c) Turbine.

**3. Why is power generation by gas turbines attractive these days?**

Gas turbines are attractive because of their ability to quickly ramp up power production.

**4. List the various factors which influence the performance of gas turbine.**

- (a) Air temperature and site elevation.
- (b) Humidity.
- (c) Inlet and exhaust losses.
- (d) Fuels.
- (e) Fuel heating.
- (f) Diluents injection.

**5. What are all modifications carried out in brayton cycle? why?**

In brayton cycles, the following devices can be incorporated to increase its thermal efficiency such as (i) regenerator (ii) reheater (iii) intercooler.

**6. When will be the gas turbine cycle efficiency reaches maximum?**

The gas turbine cycle efficiency reaches maximum when pressure ratio is equal to 1.





**7. What are the methods by which thermal efficiency of a gas turbine power plant be improved?**

- (a) Intercooler.
- (b) Reheating.
- (c) Regenerator.
- (d) Combination of inter cooling, reheating and regenerator.

**8. What is inter cooling and why it is done?**

The process of reducing the temperature of the compressed gas which reduces its volume is known as inter cooling. It is done to reduce the work done by the compressor with less volume which will reduce the input power.

**9. What is reheating of gas turbine?**

The process of supplying additional fuel between two turbines by adding fuel is called reheating.

**10. What is regeneration of gas turbine?**

The process of preheating the air which is entering the combustion chamber to reduce the fuel consumption and to increase the efficiency is known as regeneration.

**11. What is the effect of introducing regeneration in the basic gas turbine cycle?**

- (i) The fuel economy is improved. The quantity of fuel required per unit mass of air is less.
- (ii) The work output from turbine increases when the work required to the compressor will not change.

**12. When will the intercooler be provided between two compressors?**

When the pressure ratio is very high, then the intercooler is provided between compressors.

**13. What are the effects of providing the intercooler in the gas turbine cycle?**

- (i) Heat supply is increased.
- (ii) It decreases the thermal efficiency.
- (iii) Work ratio will be increased.

**14. What are the effects of reheat cycle?**

- (i) Thermal efficiency is less since the heat supplied is more.
- (ii) Turbine output is increased for the same expansion ratio.

**15. State the merits of closed cycle gas turbine over open cycle gas turbine power plant.**



- (i) Efficiency is same throughout the cycle.
- (ii) The turbine blades do not wear away since the combustion is external.

**16. State the demerits of closed cycle gas turbine over open cycle gas turbine power plant.**

- (i) A separate pre cooler arrangement is necessary.
- (ii) Initial cost is high.
- (iii) Maintenance cost is high.

**17. How the gas turbine blades are cooled?**

- (i) Drawing cooling air from compressor.
- (ii) Injection of coolant onto blade surface.
- (iii) Creating of an insulating sub layer.

**18. How does regeneration improve the thermal efficiency of gas turbine cycle?**

Regeneration reduces the energy requirement from the fuel thereby increasing the efficiency of the cycle.

**19. Depict the influence of pressure ratio on the efficiency of a Brayton cycle. (Nov 2019)**

The efficiency of a Brayton engine can be improved by: Increasing pressure ratio, as Figure 1 above shows, increasing the pressure ratio increases the efficiency of the Brayton cycle. This is analogous to the increase of efficiency seen in the Otto cycle when the compression ratio is increased.

**20. What fuel does a gas turbine use? (April 2019)**

One further advantage of gas turbines is their fuel flexibility. They can be adapted to use almost any flammable gas or light distillate petroleum products such as gasoline (petrol), diesel and kerosene (paraffin) which happen to be available locally, though natural gas is the most commonly used fuel.

**21. What is the effect of reheat on the Brayton cycle efficiency? And why? (April 2019)**

The thermal efficiency, however, when inter cooling or reheat is used in conjunction with heat regeneration, a significant increase in thermal efficiency can be achieved and the net work output is also increased.