

**V.S.B. COLLEGE OF ENGINEERING TECHNICAL
CAMPUS, COIMBATORE**
**Academic Year: 2017-2018 (EVEN Semester) Department of
Electronics and Communication Engineering Course Materials
(2013 Regulations) Question Bank**

S.No.	Name of the Subject/Lab	Semester	Page No
1	Electronic Circuits-II	IV	2
2	Communication Theory	IV	16
3	Electromagnetic Fields	IV	36
4	Linear Integrated Circuits	IV	54
5	Control System Engineering	IV	84

ELECTRONIC CIRCUITS-II

Important Part-A Questions

UNIT-I

Define feedback?

A portion of the output signal is taken from the output of the amplifier and is combined with the normal input signal. This is known as feedback.

Define positive feedback?

If the feedback signal is in phase with input signal, then the net effect of the feedback will increase the input signal given to the amplifier. This type of feedback is said to be positive or **regenerative** feedback.

3. Define negative feedback?

If the feedback signal is out of phase with the input signal then the input voltage applied to the basic amplifier is decreased and correspondingly the output is decreased. This type of feedback is known as negative or **degenerative** feedback.

4. Define sensitivity?

Sensitivity is defined as the ratio of percentage change in voltage gain with feedback to the percentage change in voltage gain without feedback.

$$dA_f/A = (dA/A)(1/1+\beta A)$$

5. What are the types of feedback?

- ⁰ Voltage-series feedback
- ¹ Voltage-shunt feedback
- ² Current-series feedback
- ³ Current-shunt feedback

What are the basic amplifiers? The

basic amplifiers are

- ⁰ Voltage amplifier
- ¹ Current amplifier
- ² Transconductance amplifier
- ³ Transresistance amplifier.

What are the components of feedback amplifier? The

components are

- ⁰ Sampling network,
- ¹ Feedback network, and
- ² mixer network.

What are two types of sampling?

- ⁰ Voltage sampling or node sampling
- ¹ Current sampling or loop sampling

State the two types of mixing?

- ⁰ Series mixing
- ¹ Shunt mixing

What is transfer gain?

It is the ratio of the output signal to the input signal. It is denoted by A

$$A = X_o / X_i$$

List out the characteristics of feedback amplifier?

- ⁰ Desensitivity
- ¹ Nonlinear distortion
- ² Noise distortion
- ³ Frequency distortion

What is the effect of input resistance due to series mixing?

The input resistance increases due to series mixing irrespective of the type of sampling. The feedback signal opposes the source signal and the **input current decreases** and due to this **input resistance increases**. $R_{if} > R_i$ Where

R_{if} = input resistance with feedback

R_i = input resistance without feedback

13. What is the effect of input resistance due to shunt mixing?

The input resistance decreases due to shunt mixing irrespective of the type of sampling. The feedback signal opposes the source signal and the input current decreases as a consequence Voltage reduces leading to a reduction in input resistance.

$$R_{if} < R_i;$$

Where R_{if} = input resistance with feedback

R_i = input resistance without feedback

What happens to output resistance due to current sampling? The

output resistance increases due to current sampling. $R_{of} > R_o$

R_{of} = input resistance with feedback

R_o = input resistance without feedback

What happens to output resistance due to voltage sampling? The output resistance decreases due to current sampling.

$R_{of} < R_o$

R_{of} = input resistance with feedback

R_o = input resistance without feedback

What happens to output resistance due to current sampling? The output resistance increases due to current sampling.

$R_{of} > R_o$

R_{of} = input resistance with feedback

R_o = input resistance without feedback

Write the expression for input and output resistance of voltage series feedback amplifier.

Input resistance with feedback, $R_{if} = R_i(1+\beta A)$

Output resistance with feedback, $R_{of} = R_o(1+\beta A)$

Give the properties of negative feedback.

⁰ Negative feedback reduces the gain

¹ Distortion is very much reduced

Give the effect of negative feedback on amplifier characteristics .

Characteristics		Types of feedback		
Current-series	Voltage-series	Voltage-shunt	Current-shunt	
Voltage gain	Decreases	Decreases	Decreases	Decreases
Bandwidth	Increases	Increases	Increases	Increases
Input resistance	Increases	Increases	Decreases	Decreases
Output Resistance	Increases	Decreases	Decreases	Increases

UNIT-II

1. What is an Oscillator?

An Oscillator is a Circuit, which generates an alternating voltage of any desired frequency. It can generate an a.c output signal without requiring any externally applied input signal.

2. What is Barkhausen criterion?

The conditions for oscillator to produce oscillation are given by Barkhausen criterion. They are:

- (i). the total phase shift produced by the circuit should be 360° or 0°
- (ii). The Magnitude of loop gain must be greater than or equal to 1 i.e. $|A \cdot \beta| \geq 1$.

What are the types of sinusoidal oscillator? Mention the different types of sinusoidal oscillator?

- ⁰ RC phase shift Oscillator.
- ¹ Wein Bridge Oscillator.
- ² Hartley Oscillator

³ Crystal Oscillator

Name two low frequency Oscillators.

- ⁰ RC phase shift.
2. Wein bridge Oscillator.

Name two high frequency Oscillators.

- i. Hartley Oscillator
- ii. Colpitts Oscillator
- iii. Crystal Oscillator

6. What did you understand by the term stability of an Oscillator? (Or) ii). Define stability of an Oscillator. (Or) iii). Why is amplitude stabilization required?

The frequency stability of an Oscillation is a measure of its ability to maintain the required frequency as precisely constant as possible over a long period of time interval.

What are the essential parts of an Oscillator?

- ⁰ Tank circuit (or) Oscillatory circuit.
- ii. . Amplifier (Transistor amplifier)
- iii. . Feedback Circuit

What are the advantages of Rc phase shift Oscillator?

- ⁰ It is best suited for generating fixed frequency signals in the audio frequency range.
- ii. Simple Circuit.
- iii Pure sine wave output is possible.

What is piezo electric effect?

The piezo electric Crystals exhibit a property that if a mechanical stress is applied across one face the electric potential is developed across opposite face. The inverse is also live. This phenomenon is called piezo electric effect.

What are the equivalent circuit parameters of a Crystal.

Where

- R = internal frictional losses.
- L = Mass of the crystal.
- Cs = Stiffness of the crystal.
- Cp = Shunt capacitance.

List the disadvantages of crystal Oscillator.

- ⁰ It is suitable for only low power circuits
- ¹ Large amplitude of vibrations may crack the crystal.
- ² It large in frequency is only possible replacing the crystal with another one by different frequency.

What is meant by resonant Circuit Oscillators?

LC Oscillators are known as resonant circuit oscillator because the frequency of operation of LC Oscillator is nothing but a resonant frequency of tank circuit or LC tank circuit produces sustained Oscillation at the resonant circuit oscillator.

Classify the different types of Oscillators. i.

According to waveform generation a.

- a. Sinusoidal Oscillator.
- b. Relaxation Oscillator.

ii. According to the fundamental mechanism involved

- a. Negative resistance Oscillator.
- b. Feedback Oscillator.

iii. According to frequency generated

- a. Audio frequency Oscillator (Up to 20KHZ)
- b. Radio frequency Oscillator (20KHZ)
- c. Very high frequency oscillator (30 MHZ to 300 MHZ).
- d. Ultra high frequency Oscillator (300 MHX to 3 GHZ).
- e. Microwave frequency Oscillator (> 3 GHZ).

iv. According to type coupling.

- a. LC Oscillator.
- b. RC Oscillator.

Why RC phase shift is needed in a RC phase shift Oscillator?

The amplifier used causes a phase shift of 180o than the feedback network should create phase shift of 180o, to satisfy the Barkhausen Criterion. Hence in a phase shift oscillators, three sections of RC circuit are connected in cascade, each introducing a shift of 60o, thus introducing a total phase shift of 180o, due to feedback network.

15. What are the advantages of crystal Oscillators over other Oscillator?

To maintain the output frequency of an oscillator at a constant value, a crystal may be used to control the frequency of oscillation.

16. What is negative resistance? Name a few devices which offer this resistance.

It is defined as the resistance of a device which offers when operated in the negative resistance region.

Ex: - Tunnel diodes, UJT... Etc.,

17. Define gain and phase Margin.

Gain Margin: It is defined as the value of $|A\beta|$ in decibels at the frequency at which the phase angle of $A\beta$ is 180o, negative gain margin signifies decibel rise in open loop gain a theoretical possibility without oscillation. A positive gain margin signifies that amplifier is potentially unstable.

Phase Margin: It is defined as 180o minus the Magnitude of angle of $A\beta$ at the frequency at which $|A\beta|$ is unity.

18. What is a beat frequency oscillator?

Beat frequency Oscillator (BFO) is an Oscillator in which a desired signals frequency such as the beat frequency produced by combining the different signal frequencies such as on different radio frequencies.

19. what is frequency stability of oscillator?

The ability to measure the the stability of frequency over a long period of time & as long as same desired frequency is measured.

UNIT-III

1. What is a tuned amplifier?

The amplifier with a circuit that is capable of amplifying a signal over a narrow band of frequencies are called tuned amplifiers.

What is the expression for resonant frequency?

$$f_r = \frac{1}{2\pi \sqrt{LC}}$$

What happens to the circuit above and below resonance?

Above resonance the circuit acts as capacitive and below resonance the circuit acts as inductive.

What are the different coil losses? Hysteresis loss

- ⁰ Copper loss
- ¹ Current loss

What is Q factor?

6. What is dissipation factor?

What is the classification of tuned amplifiers?

- ⁰ Single tuned
- ¹ Double tuned
- ² Stagger tuned

is a single tuned amplifier?

An n amplifier circuit that uses a single parallel tuned circuit as a load is called single tuned amplifier.

What are the advantages of tuned amplifiers

- ⁰ They amplify defined frequencies.
- ¹ Signal to noise ratio at output is good
- ² They are suited for radio transmitters and receivers

What are the disadvantages of tuned amplifiers?

- ⁰ The design is complex,
- ¹ They are not suited to amplify audio frequencies.

What is neutralization?

The effect of collector to base capacitance of the transistor is neutralized by introducing a signal that cancels the signal coupled through collector base capacitance. This process is called neutralization.

12. What are double tuned amplifiers?

The amplifiers having two parallel resonant circuit in its load are called double tuned amplifiers.

13. What is a stagger tuned amplifier?

It is a circuit in which two single tuned cascaded amplifiers having certain bandwidth are taken and their resonant frequencies are adjusted that they are separated by an amount equal to the bandwidth of each stage. Since resonant frequencies are displaced it is called stagger tuned amplifier.

14. What are the advantages of stagger tuned amplifier?

The advantage of stagger tuned amplifier is to have better flat, wideband characteristics.

What are the advantages of double tuned over single tuned?

- ⁰ Possess flatter response having steeper sides
 - ¹ Provides larger 3 db bandwidth
- Provides large gain-bandwidth product.

What are the different types of neutralization?

- ⁰ Hazeltine neutralization
- ¹ Rice neutralization
- ² Neutrodyne neutralization.

What is rice neutralization?

It uses center tapped coil in the base circuit. The signal voltages at the end of tuned base coil are equal and out of phase.

18. What is unloaded Q?

It is the ratio of stored energy to the dissipated energy in a reactor or resonator.

19. What are the applications of mixer circuits?

Used in radio receivers. Used to translate signal frequency to some lower frequency

20. What is up converter?

When the mixer circuit is used to translate signal to high frequency, then it is called up converter.

21. What is an amplifier?

An amplifier is a device which produces a large electrical output of similar characteristics to that of the input parameters.

How are amplifiers classified according to the input?

- ⁰ Small – signal amplifier
- 2. Large – signal amplifier

How are amplifiers classified according to the transistor configuration?

- ⁰ Common emitter amplifier
- 2. Common base amplifier
- 3. Common collector amplifier

What is the different analysis available to analyze a transistor?

- ⁰ AC analysis
- 2. DC analysis

How can a DC equivalent circuit of an amplifier be obtained?

By open circuiting the capacitor.

26. How can a AC equivalent circuit of a amplifier be obtained?

By replacing dc supply by a ground and short- circuiting capacitors.

UNIT-IV

1. What is a Multivibrator?

The electronic circuits which are used to generate nonsinusoidal waveforms are called Multivibrators.

2.Name the types of Multivibrators?

Bistable Multivibrator, Monostable Multivibrator,Astable Multivibrator

3.How many stable states do bistable Multivibrator have?

Two stable states.

4.When will the circuit change from stable in bistable multi vibrator?

When an external trigger pulse is applied, the circuit changes from one stable state to another.

5.What are the different names of bistable Multivibrator?

Eccles Jordan circuit, trigger circuit, scale-of-2 toggle circuit, flip-flop and binary.

6. What are the applications of bistable Multivibrator?

It is used in the performance of many digital operations such as counting and storing of the Binary information. It also finds applications in the generation and processing of pulse – type waveforms

7. What are the other names of monostable Multivibrator?

One-shot, Single-shot, a single-cycle, a single swing, a single step Multivibrator, Univibrator.

8. Why is monostable Multivibrator called gating circuit?

The circuit is used to generate the rectangular waveform and hence can be used to gate other Circuits hence called gating circuit.

9. Why is monostable Multivibrator called delay circuit?

The time between the transition from quasi-stable state to stable state can be predetermined and hence it can be used to introduce time delays with the help of fast transition. Due to this application is Called delay circuit.

10.What is the main characteristics of Astable Multivibrator

The Astable Multivibrator automatically makes the successive transitions from one quasi-stable State to other without any external triggering pulse.

11.What is the other name of Astable Multivibrator- why is it called so?

As it does not require any external pulse for transition, it is called free running Multivibrator.

12.What are the two types of transistor bistable Multivibrator?

- i. Fixed bias transistor circuit
- ii. Self bias transistor circuit.

13.Why does one of the transistor start conducting ahead of other?

The characteristic of both the transistors are never identical hence after giving supply one of the transistors start conducting ahead of the other.

14.What are the two stable states of bistable Multivibrator?

- i. Q1 OFF (cut off) and Q2 ON (Saturation)
- ii. Q2 OFF (Cut off) and Q1 On (Saturation)

15.What finally decides the shape of the waveform for bistable multivibrator? The spacing of the triggering pulses

16. How are the values R1, R2 and VBB chosen in bistable Multivibrator?

It is chosen in such a way that in one state the base current is large enough to drive the transistor into saturation while in other state the emitter junctions is well below off.

17. What is the self biased Multivibrator?

The need for the negative power supply in fixed bias bistable Multivibrator can be eliminated by rising a common emitter resistance RE. The resistance provides the necessary bias to keep one transistor or and the other OFF in the stable state such type of biasing is called self biasing and the circuit is called self biased bistable Multivibrator.

18. What are the other names of speed up capacitors.

- i. Commutating Capacitors
- ⁰ Transpose capacitors

Define transition time?

It is defined as the time interval during which conduction transfers from one transistor to other.

20. What is the value of commutating capacitor.

It lies in the range of tens to some hundreds of Pico farads.

21. Define resolving time.

The smallest allowable interval between triggers is called resolving time.

Give the expression of fmax with respect to resolving time

$f_{max} = 1/\text{resolving time.}$

23. Define gate width

The pulse width is the time for which the circuit remains in the quasi stable state. It is also called gate width.

What are the advantages of monostable Multivibrator.

- ⁰ used to introduce time delays as gate width is adjustable
- ¹ used to produce rectangular waveform and hence can be used

What are the applications of astable Multivibrator.

- ⁰ used as a clock for binary logic signals
- ¹ used as a square wave generator, voltage to frequency converter.

26. What is a complementary Multivibrator

It is turning half the circuit upside down. So one transistor is n-p-n while the other is p-n-p. The circuit is called complementary Multivibrator circuit.

27. What is UTP of the Schmitt trigger

When Vi reaches to VBE1 +VE the Q1 gets driven to active region. This input voltage level is called upper threshold point.

What is the other name for UTP

It is also called input turn on threshold level.

29. What is LTP Schmitt trigger.

The level of Vi at which Q1 becomes OFF and Q2 on is called lower threshold point.

30. Define transfer Characteristics

The graph of output voltage against input voltage is called transfer characteristics of Schmitt trigger.

31. What is the important application of Schmitt trigger?

- ⁰ It is used as an amplitude comparator
- ¹ It is used as a squaring circuit.

UNIT-V

1. Define Blocking Oscillator?

A special type of wave generator which is used to produce a single narrow pulse or train of pulses.

What are the two important elements of Blocking Oscillator?

Transistor and pulse transformer

What are the applications of blocking Oscillator?

It is used in frequency dividers, counter circuits and for switching the other circuits.

Give the expression for co-efficient of coupling

$$K = M / \sqrt{L_p L_s}$$

M -> Mutual Inductance L_p

-> Primary Inductance L_s

-> Secondary Inductance

Give the formula for transformation ratio

$$n = N_s / N_p = \text{transformation ratio}$$

N_s = Secondary Turns;

N_p = Primary turns

6. Define rise time

It is defined by the time required by the pulse to rise from 10% of its amplitude to 90% of its amplitude.

7. Define overshoot.

It is the amount by which the output exceeds its amplitude during first attempt.

8. Define flat top response

The position of the response between the trailing edge and the leading edge.

9. Define droop or a tilt

The displacement of the pulse amplitude during its flat response is called droop or tilt.

What are the applications of pulse transformer.

⁰ to invert the polarity of the pulse

¹ to differentiate pulse

When do the core saturates?

12. What is the other name of astable Blocking Oscillator

Free running blocking Oscillator

13. What are the two types of astable Blocking Oscillator?

1. Diode controlled Astable Blocking Oscillator.

⁰ Re controlled Astable Blocking Oscillator.

Define Sweeptime in sawtooth generator

The period during which voltage increases linearly is called sweep time.

15. Define Displacement error in the sawtooth generator?

It is defined as the maximum difference between the actual sweep voltage and linear sweep which passes through the beginning and end points of the actual sweep.

16. What is constant current charging?

A capacitor is charged with a constant current source.

17. What is the miller circuit

Integrator is used to convert a step waveform into ramp waveform.

18. Define rise time

It is defined by the time required by the pulse to rise from 10% of its amplitude to 90% of its amplitude.

19. Define overshoot.

It is the amount by which the output exceeds its amplitude during first attempt.

20. Define flat top response.

The position of the response between the trailing edge and the leading edge.

21. Define droop or a tilt

The displacement of the pulse amplitude during its flat response is called droop or

tilt.

What are the applications of pulse transformer.

⁰ to invert the polarity of the pulse

¹ to differentiate pulse

Important Part-B Questions

UNIT-I

What will happen when a step input voltage is applied to the high pass RC Circuit?

Explain the relevant information, how the negative feedback improves stability reduce noise and increase input impedance?

Explain voltage shunt feedback amplifiers?

Explain current series feedback amplifiers?

Explain the classification of amplifiers?

Explain current shunt and voltage shunt feedback amplifiers?

Compare the types of feedback topologies with respect to basic amplifier, R_{if} and R_{of} . Draw example circuit for each type of feedback.

Draw the feedback topology block diagram with voltage series feedback and derive the input impedance

Give the block diagram of feedback amplifier and discuss the effect of negative feedback with respect to closed loop gain, bandwidth and distortion.

Explain Nyquist criterion to analyze the stability of feedback amplifiers.

Show how negative feedback reduces gain of an amplifier.

Explain the effect of negative feedback on the input resistance for a voltage shunt feedback amplifiers.

Derive the expression for A_{vf} with positive feedback and negative feedback and state condition for stability in negative feedback amplifiers.

Derive the circuit of an emitter follower. Identify the type of negative feedback, calculate the gain, input and output resistance with and without feedback.

Draw the block diagram of voltage series feedback amplifier and derive for A_{vf} , R_{if} , and R_{of} . Draw a two stage amplifier with voltage series feedback.

UNIT-II

With simple diagrams explain the operation of negative resistance oscillator using tunnel diode?

Explain RC phase shift oscillator?

Explain Clapp's oscillator and derive the expression for frequency of oscillation. Also explain how

frequency stability can be improved Clapp's oscillator.

Explain Hartly oscillator and derive the equation for oscillation?

Explain pierce crystal oscillator and derive the equation for oscillation?

Explain the Colpitt oscillator, derive its frequency of oscillation.

Explain RC phase shift oscillator with neat circuit diagram. Derive its frequency of oscillation.

Give the amplifier gain and feedback network gain to sustain oscillator.

Explain Clapp oscillator and derive their frequency of oscillation.

Explain Wein bridge oscillator circuit and derive its frequency of oscillation.

Explain Armstrong oscillator and derive its frequency of oscillation.

UNIT-III

Explain in detail about single tuned amplifier.

Explain in detail about double tuned amplifier.

Explain in detail about stagger-tuned amplifier

Compare single tuned and double tuned amplifier

Explain the different types of neutralization?

With equivalent circuit of single tuned amplifier derive the gain as function of frequency.

Derive the cut off frequencies.

What is the need for neutralization? Explain Hazeltine neutralization?

Define Class-C amplifier. Sketch a tuned class-C amplifier with an LC tank circuit as load.

Derive its efficiency.

What are synchronous and stagger tuned amplifier circuits.

Discuss the effect of bandwidth on cascading single tuned amplifiers.

UNIT-IV

Explain bistable Multivibrator and its types?

Explain about speedup capacitors or commutating capacitors.

Explain about Monostable Multivibrator.

Explain about collector coupled astable Multivibrator.

Explain emitter coupled astable Multivibrator.

Write in detail about Schmitt Trigger circuit?

With neat circuit diagram explain the working of monostable multivibrator. Derive its on time.

Draw the base and collector signals.

With neat circuit diagram explain the working of astable multivibrator. Derive its time period.

Draw the base and collector waveforms.

With neat circuit diagram, explain the working of Schmitt trigger circuit. Draw the corresponding waveforms.

Sketch and define transistor switching times.

What is the response of low pass RC circuit for sinusoidal, Step, pulse, square wave and ramp inputs.

UNIT-V

Explain about pulse transformer?

Explain Monostable blocking oscillator using emitter timing?

Write about the core saturation method.

Write about astable blocking oscillator.

Write about UJT saw tooth generator.

Explain Bootstrap time base sweep generator with circuit diagram and waveform derive for its output voltage.

Draw the circuit for generating sweep using UJT switch and explain its operation. Give expression for sweep period and frequency.

Explain miller and Bootstrap sweep generators with necessary circuits and waveforms.

With neat circuit diagram, Explain monostable blocking oscillators with base and emitter timing. Draw necessary waveforms.

Draw the circuit of a current time base generator, explain how the circuit operates.

Explain about astable blocking oscillator with base timing.

COMMUNICATION THEORY

2 MARKS QUESTION WITH ANSWERS

UNIT I AMPLITUDE MODULATION SYSTEMS

1. Define modulation?

Modulation is a process by which some characteristics of high frequency carrier signal is varied in accordance with the instantaneous value of the modulating signal.

What are the types of analog modulation?

- 0 Amplitude modulation.
- 1 Angle Modulation
- 2 Frequency modulation
- 3 Phase modulation.

Define depth of modulation.

It is defined as the ratio between message amplitude to that of carrier amplitude. $m = E_m/E_c$

What are the degrees of modulation?

- 0 Under modulation. $m < 1$
- 1 Critical modulation $m = 1$
- 2 Over modulation $m > 1$

What is the need for modulation?

Needs for modulation:

0	Ease of transmission
1	Multiplexing
2	Reduced noise
3	Narrow bandwidth
4	Frequency assignment
5	Reduce the equipments limitations

What are the types of AM modulators?

There are two types of AM modulators. They are 1.Linear modulators 2.Non-linear modulators Linear modulators are classified as follows • Transistor modulator

There are three types of transistor modulator. • Collector modulator • Emitter modulator • Base modulator • Switching modulators

Non-linear modulators are classified as follows • Square law modulator • Product modulator
Balanced modulator

7. What is the difference between high level and low level modulation?

In high level modulation, the modulator amplifier operates at high power levels and delivers power directly to the antenna. In low level modulation, the modulator amplifier performs modulation at relatively low power levels. The modulated signal is then amplified to high power level by class B power amplifier. The amplifier feeds power to antenna.

8. Define Detection (or) Demodulation.

Detection is the process of extracting modulating signal from the modulated carrier. Different types of detectors are used for different types of modulations.

9. Define Amplitude Modulation.

In amplitude modulation, the amplitude of a carrier signal is varied according to variations in amplitude of modulating signal. The AM signal can be represented mathematically as, $e_{AM} = (E_c + E_m \sin \omega_m t) \sin \omega_c t$ and the modulation index is given as, $m = E_m / E_c$ (or) V_m / V_c

10. What is Super Heterodyne Receiver?

The super heterodyne receiver converts all incoming RF frequencies to a fixed lower frequency, called intermediate frequency (IF). This IF is then amplitude and detected to get the original signal.

11. What is single tone and multi tone modulation?

If modulation is performed for a message signal with more than one frequency component then the modulation is called multi tone modulation. If modulation is performed for a message signal with one frequency component then the modulation is called single tone modulation.

12. Compare AM with DSB-SC and SSB-SC.

S.No.	AM signal	DSB-SC	SSB-SC
1	Bandwidth = $2f_m$	Bandwidth = $2f_m$	Bandwidth = f_m
2	Contains USB, LSB, Carrier	Contains USB, LSB	USB, LSB
3	More Power is required for transmission	Power required is less than that of AM.	Power required is less than AM & DSB-SC

What are the advantages of VSB-AM?

- ⁰ It has bandwidth greater than SSB but less than DSB system.
- ¹ Power transmission greater than DSB but less than SSB system.
- ² No low frequency component lost. Hence it avoids phase distortion.

14. How will you generating DSBSC-AM?

There are two ways of generating DSBSC-AM such as

- a).Balancedmodulator
- b).Ring modulators.

What are advantages of ring modulator?

- a).Its output is stable.
- b). It requires no external power source to activate the diodes.
- c).Virtually no maintenance.
- d). Long life.

Define Demodulation.

Demodulation or detection is the process by which modulating voltage is recovered from the modulated signal. It is the reverse process of modulation. The devices used for demodulation or detection are called demodulators or detectors. For amplitude modulation, detectors or demodulators are categorized as,

- Square-law detectors
- Envelope detectors

17. Define Multiplexing.

Multiplexing is defined as the process of transmitting several message signals Simultaneously over a single channel.

18. Define Frequency Division Multiplexing.

Frequency division multiplexing is defined as many signals are transmitted simultaneously with each signal occupying a different frequency slot within a common bandwidth.

19. Define Guard Band.

Guard Bands are introduced in the spectrum of FDM in order to avoid any interference between the adjacent channels. Wider the guard bands, Smaller the interference.

Define SSB-SC.

⁰ SSB-SC stands for Single Side Band Suppressed Carrier

¹ When only one sideband is transmitted, the modulation is referred to as Single side band modulation. It is also called as SSB or SSB-SC.

Define DSB-SC.

After modulation, the process of transmitting the sidebands (USB, LSB) alone and suppressing the carrier is called as Double Side Band-Suppressed Carrier.

What are the disadvantages of DSB-FC?

- ⁰ Power wastage takes place in DSB-FC
- ¹ DSB-FC is bandwidth inefficient system.

Define Coherent Detection.

During Demodulation carrier is exactly coherent or synchronized in both the frequency and phase, with the original carrier wave used to generate the DSB-SC wave. This method of detection is called as coherent detection or synchronous detection.

24. What is Vestigial Side Band Modulation?

Vestigial Sideband Modulation is defined as a modulation in which one of the sideband is partially suppressed and the vestige of the other sideband is transmitted to compensate for that suppression.

What are the advantages of signal sideband transmission?

- ⁰ Power consumption
- ¹ Bandwidth conservation
- ² Noise reduction

What are the disadvantages of single side band transmission?

- ⁰ Complex receivers: Single side band systems require more complex and expensive receiver's than conventional AM transmission.
- ¹ Tuning difficulties: Single side band receivers require more complex and precise tuning than conventional AM receivers.

Compare linear and non-linear modulators?

- ⁰ Heavy filtering is not required.
 - ¹ These modulators are used in high level modulation.
 - ² The carrier voltage is very much greater than modulating signal voltage.
- Non Linear Modulators
- ³ Heavy filtering is required.
 - ⁴ These modulators are used in low level modulation.
 - ⁵ The modulating signal voltage is very much greater than the carrier signal voltage.

What is frequency translation?

Suppose that a signal is band limited to the frequency range extending from a frequency f_1 to a frequency f_2 . The process of frequency translation is one in which the original signal is replaced with a new signal whose spectral range extends from f_1' and f_2' and which new signal bears, in recoverable form the same information as was borne by the original signal.

What are the two situations identified in frequency translations?

⁰ Up Conversion: In this case the translated carrier frequency is greater than the incoming carrier

¹ Down Conversion: In this case the translated carrier frequency is smaller than the increasing carrier frequency. Thus, a narrowband FM signal requires essentially the same transmission bandwidth as the AM signal.

What is BW for AM wave?

The difference between these two extreme frequencies is equal to the bandwidth of the AM wave. Therefore, Bandwidth, $B = (f_c + f_m) - (f_c - f_m)$ $B = 2f_m$

31. What is the BW of DSB-SC signal?

Bandwidth, $B = (f_c + f_m) - (f_c - f_m)$ $B = 2f_m$ It is obvious that the bandwidth of DSB-SC modulation is same as that of general AM waves.

32. What are the demodulation methods for DSB-SC signals?

The DSB-SC signal may be demodulated by following two methods:

- (i) Synchronous detection method.
- (ii) Using envelope detector after carrier reinsertion.

Write the applications of Hilbert transform?

- ⁰ For generation of SSB signals,
- ¹ For designing of minimum phase type filters,
- ² For representation of band pass signals.

What are the methods for generating SSB-SC signal?

- SSB-SC signals may be generated by two methods as under:
- (i) Frequency discrimination method or filter method.
 - (ii) Phase discrimination method or phase-shift method.

**UNIT-II
ANGLE MODULATION**

What do you understand by narrowband FM?

When the modulation index is less than 1, the angle modulated systems are called low index. The bandwidth requirement of low index systems is approximately twice of the modulating.

2. Define frequency modulation.

Frequency modulation is defined as the process by which the frequency of the carrier wave is varied in accordance with the instantaneous amplitude of the modulating or message signal.

3. Define modulation index of frequency modulation.

It is defined as the ratio of maximum frequency deviation to the modulating $\beta = \delta f f_m$

4. What do you meant by multitone modulation?

Modulation done for the message signal with more than one frequency component is called multitone modulation.

5. Define phase modulation.

Phase modulation is defined as the process of changing the phase of the carrier signal in accordance with the instantaneous amplitude of the message signal.

6. What are the types of Frequency Modulation?

Based on the modulation index FM can be divided into types. They are Narrow band FM and Wide band FM. If the modulation index is greater than one then it is wide band FM and if the modulation index is less than one then it is Narrow band FM.

7. What is the basic difference between an AM signal and a narrowband FM signal?

In the case of sinusoidal modulation, the basic difference between an AM signal and a narrowband FM signal is that the algebraic sign of the lower side frequency in the narrow band FM is reversed.

8. What are the two methods of producing an FM wave?

Basically there are two methods of producing an FM wave. They are,

⁰ Direct method: In this method the transmitter originates a wave whose frequency varies as function of the modulating source. It is used for the generation of NBFM

¹ Indirect method: In this method the transmitter originates a wave whose phase is a function of the modulation. Normally it is used for the generation of WBFM where WBFM is generated from NBFM.

Compare WBFM and NBFM.

S.No.	WBFM	NBFM
1.	Modulation index is greater than 1	Modulation index less than 1
2.	Frequency deviation 75 KHz	Frequency deviation 5 KH
3.	Bandwidth 15 times NBFM	Bandwidth 2fm

4.	Noise is more suppressed	Less suppressing of noise
----	--------------------------	---------------------------

10. Give the average power of an FM signal.

The amplitude of the frequency modulated signal is constant .The power of the FM signal is same as that of the carrier power.

11. Define phase deviation.

The maximum phase deviation of the total angle from the carrier angle is called phase deviation.

12. Define frequency Deviation.

The maximum departure of the instantaneous frequency from the carrier frequency is called frequency deviation.

13. State the Carson’s rule.

An approximate rule for the transmission bandwidth of an FM Signal generated by a single tone-modulating signal of frequency f_m (max) is defined as $\therefore BW=2[f_c + f_m(max)]$

14. Define the deviation ratio D for non-sinusoidal modulation.

The deviation ratio D is defined as the ratio of the frequency deviation f_d , which Corresponds to the maximum possible amplitude of the modulation signal $m(t)$, to the highest modulation frequency. $D = \Delta f / f_m$

15. What is the use of crystal controlled oscillator?

The crystal-controlled oscillator always produces a constant carrier frequency thereby enhancing frequency stability.

What are the disadvantages of FM system?

- ⁰ A much wider channel is required by FM.
- ¹ FM transmitting and receiving equipments tend to be more complex and hence it is expensive.

How will you generate message from frequency-modulated signals?

First the frequency-modulated signals are converted into corresponding amplitude modulated signal using frequency dependent circuits. Then the original signal is recovered from this AM signal.

What are the types of FM detectors? The

- types of FM detectors are
- (i) Slope detector and

⁰ Phase discriminator.

What are the types of phase discriminator? The

types of phase discriminator are

⁰ Foster seeley discriminator and

¹ Ratio detector.

What are the disadvantages of balanced slope detector? 1.

Amplitude limiting cannot be provided

2. Linearity is not sufficient

3. It is difficult to align because of three different frequencies to which various tuned circuits to be tuned.

The tuned circuit is not purely band limited.

Write the advantages and disadvantages of foster-seely discrimination method?

Advantages:

a) It is much easier to design

b) Only two tuned circuits are necessary and they are tuned to same frequency c) Linearity is better

Disadvantages:

a) It requires Amplitude limiting circuit.

What are the applications of phase locked loop?

Phase locked loops are used for various purposes in AM and FM communication.

(i) Automatic frequency correction in FM transmitter uses PLL to keep carrier frequency constant.

(ii) PLL is used direct FM Transmitter uses PLL to keep carrier frequency constant.

(iii) PLL is also used in FM demodulators.

Differentiate phase and frequency modulation.

Phase Modulation

Phase of the carrier varies as per amplitude variations of modulating signal. Instantaneous phase deviation, $(t) = k_e m(t)$

Modulation index = $k_e E_m$

Frequency Modulation

Frequency of the carrier varies as per amplitude variations of modulating signals.

Instantaneous frequency deviation, $\Delta(t) = k_f m(t)$

Modulation index = $k_f E_m$

A 80 MHz carrier is frequency modulated by a sinusoidal signal of 1V amplitude and the frequency sensitivity is 100 Hz/V. Find the approximate bandwidth of the FM waveform if the modulating signal has a frequency of 10 kHz.

Frequency Sensitivity = 100 Hz/ volt. Amplitude of modulating signal = 1V Hence maximum frequency deviation, $\delta = 100 \text{ Hz / volt} \times 1\text{V} = 100 \text{ kHz}$ Frequency of modulating signal, f_m

$10\text{kHz} \therefore \text{BW} = 2 [f_c + f_m (\text{max})] = 2 [100 + 10 \times 10^3] \text{ BW} = 20.2 \text{ kHz}$

25. What is diversity reception?

Diversity reception is used when the signal fades into noise level. There are two types of diversity reception:

⁰ Space diversity

¹ Frequency diversity.

Space diversity:

It uses two or more receiving antennas separated by nine or more wavelengths. These are separate receivers for each antenna. The receiver with strongest signal is selected.

b) Frequency diversity:

It uses single receiving antenna which works for two or more frequencies. The frequency which has strong signal is selected.

State the disadvantages of FM.

⁰ Bandwidth requirement of FM is much higher.

¹ FM transmitting and receiving equipment is more complex and costly.

² Distance of reception is limited only to line of sight.

What do you understand by FM stereo multiplexing?

FM stereo multiplexing is used for stereo transmission. It is basically frequency division multiplexing. It is used for FM radio broadcasting. The left and right channel signals are used to generate sum and difference signals. The difference signal frequency modulates the carrier. The difference signal, FM difference signal, FM difference signal and carrier are combined together and sent. Such FM multiplexed signal can be coherently received by stereo as well as mono receiver.

UNIT – III RANDOM PROCESS

1. Define random variables.

A random variable, usually written X, is a variable whose possible values are numerical outcomes of a random phenomenon. Random variable consists of two types they are discrete and continuous type variables.

2. What is meant by probability distribution?

The probability distribution of a discrete random variable is a list of probabilities associated with each of its possible values. It is also sometimes called the probability function or the probability mass function.

What are the conditions applied in the central limit theorem?

The mean of the population of means is always equal to the mean of the parent population from which the population samples were drawn.

0.0 The standard deviation of the population of means is always equal to the standard deviation of the parent population divided by the square root of the sample size (N).

The distribution of means will increasingly approximate a normal distribution as the size N of samples increases.

¹ **Define stationary process.**

Stationary process is a stochastic process whose joint probability distribution does not change when shifted in time. Consequently, parameters such as the mean and variance, if they are present, also do not change over time and do not follow any trends.

5. Write the equation for correlation?

The population correlation coefficient $\rho_{X,Y}$ between two random variables X and Y with expected values μ_X and μ_Y and standard deviations σ_X and σ_Y .

6. What is meant by covariance?

Covariance is a measure of how much two variables change together, and the covariance function, or kernel, describes the spatial covariance of a random variable process or field.

7. Define random process.

A random process X(t) is a Gaussian process if for all n and all (t1 ,t2 ,...,tn), the random variables have a jointly Gaussian density function.

8. Write the equation of Autocorrelation?

The autocorrelation function of the output random process Y (t). By definition, we have $R_Y(t, u) = E[Y(t)Y(u)]$ where t and u denote the time instants at which the process is observe.

9. Write the applications of random process?

The available noise power is directly proportional to temperature and it is independent of value of resistance. This power specified in terms of temperature is called as noise temperature. It is denoted by T_e .

It is given as, $\bullet T_e = (F-1) T$ A Gaussian process can be used as a prior probability distribution over functions in Bayesian inference.
 \bullet Wiener process (aka Brownian motion) is the integral of a white noise Gaussian process. It is not stationary, but it has stationary increments.

Mention the types of mathematical models.

There are two types:

- ⁰ Deterministic model

¹ Stochastic model

What is mean by events, sample space?

The set of all possible outcomes is called the sample space.

Events are subsets of the sample space.

12. Define probability.

Probability is defined as a set function assigning non negative values to all events E.

Probability $P(E) = \text{Number of possible favorable outcomes} / \text{Total number of outcomes}$.

List the types of Random Variables.

- ⁰ Bernouli random
- ¹ Binomial random variable
- ² Uniform random variable
- ³ Gaussian or normal random variable

State the Wiener Khinchin theorem.

This theorem states that for a stationary random process $X(t)$, the power spectral density is the fourier transform of the autocorrelation function, that is

$$S_x(f) = F (R_x(f))$$

15. Define Gaussian process.

A Gaussian process is a stochastic process for which any finite linear combination of samples will be normally distributed.

Give any two advantages of Gaussian process.

- ⁰ The Gaussian process has many properties make analytic results possible.
- ¹ The random process produced by physical phenomena often such that a Gaussian model is appropriate.

Define central limit theorem.

The Central Limit Theorem describes the characteristics of the "population of the means" which has been created from the means of an infinite number of random population samples of size (N), all of them drawn from a given "parent population". The Central Limit Theorem predicts that regardless of the distribution of the parent population:

The mean of the population of means is always equal to the mean of the parent population from which the population samples were drawn.

⁰ The standard deviation of the population of means is always equal to the standard deviation of the parent population divided by the square root of the sample size (N).

¹ The distribution of means will increasingly approximate a normal distribution as the size N of samples increases.

What is meant by stationary process?

In mathematics and statistics, a stationary process is a stochastic process whose joint probability distribution does not change when shifted in time. Consequently, parameters such as the mean and variance, if they are present, also do not change over time and do not follow any trends. Stationary is used as a tool in time series analysis, where the raw data is often transformed to become stationary.

UNIT-IV NOISE CHARACTERISATION

1. Define noise.

Noise is defined as any unwanted form of energy, which tends to interfere with proper reception and reproduction of wanted signal.

2. Give the classification of noise.

Noise is broadly classified into two types.

They are

⁰ External noise

¹ Internal noise.

What are the types of External noise?

External noise can be classified into

1. Atmospheric noises

⁰ Extraterrestrial noises

¹ Man –made noises or industrial noises

What are types of internal noise?

Thermal noise

Shot noise

⁰ Transit time noise

¹ Miscellaneous internal noise

What are the types of extraterrestrial noise and write their origin?

The two types of extraterrestrial noise are solar noise and cosmic noise. Solar noise is the electrical noise emanating from the sun. Cosmic noise is the noise received from the center part of our galaxy, other distant galaxies and other virtual point sources.

6. Define transit time of a transistor.

Transit time is defined as the time taken by the electron to travel from emitter to the collector.

7. Define flicker noise.

Flicker noise is the one appearing in transistors operating at low audio frequencies. Flicker noise is proportional to the emitter current and junction temperature and inversely proportional to the frequency.

State the reasons for higher noise in mixers.

⁰ Conversion transconductance of mixers is much lower than the transconductance of amplifiers.

¹ If image frequency rejection is inadequate, the noise associated with the image frequency also gets accepted.

Define signal to noise ratio.

Signal to noise ratio is the ratio of signal power to the noise power at the same point in a system.

10. Define thermal noise.

The expression for the thermal noise is the voltage across a resistor. The electrons in a conductor possess varying amounts of energy. A small fluctuation in this energy produces small noise voltages in the conductor. These random fluctuations produced by thermal agitation of the electrons is called thermal noise.

11. Define noise temperature.

The available noise power is directly proportional to temperature and it is independent of value of resistance. This power specified in terms of temperature is called as noise temperature. It is denoted by T_e . It is given as, $T_e = (F - 1) T$

12. What is shot noise?

When current flows in electronic device, the fluctuations number of electrons or holes generates the noise. It is called shot noise. Shot noise also depends upon operating conditions of the device.

Give the expression for noise voltage in a resistor.

The Mean-Square value of thermal noise voltage is given by, $V_n = \sqrt{4kTB}$ where k – Boltzmann constant, R – Resistance, T – Absolute temperature, B Bandwidth.

14. What is White Noise?

Many types of noise sources are Gaussian and have flat spectral density over a wide frequency range. Such spectrum has all frequency components in equal portion, and is therefore called white noise. The power spectral density of white noise is independent of the operating frequency. The Power spectral density of White Noise is given as, $S(f) = N_0/2$.

15. What is narrowband noise?

The receiver of a communication system usually includes some provision for preprocessing the received signal. The preprocessing may take the form of a narrowband filter whose bandwidth is large enough to pass modulated component of the received signal essentially undistorted but not so large as to admit excessive noise through the receiver. The noise process appearing at the output of such filter is called narrow band noise.

The noise equivalent bandwidth of the filter is defined as the bandwidth of an ideal filter at which the noise power passed by real filter and ideal filter is same.

17. Define noise factor.

Noise factor (F) is defined as the ratio of signal to noise power ratio at the input to signal to noise power ratio at the output.

Give the characteristics of shot noise.

Shot noise is generated due to fluctuations in the number of electrons or holes.

Shot noise has uniform spectral density.

Mean square noise current depends upon direct component of current.

1.0 Shot noise depends upon operating conditions of the device.

What is FM threshold effect?

As the carrier to noise ratio is reduced, clicks are heard in the receiver output. As the carrier to noise ratio reduces further, crackling, or sputtering sound appears at the receiver output. Near the breaking point, the theoretically calculated output signal to noise ratio becomes large, but its actual value is very small. This phenomenon is called threshold effect.

20. What is capture effect in FM?

When the noise interference is stronger than FM signal, then FM receiver locks to interference. This suppresses FM signal. When the noise interference as well as FM signal are of equal strength, then the FM receiver locking fluctuates between them. This phenomenon is called capture effect.

What is meant by figure of merit of a receiver?

The ratio of output signal to noise ratio to channel signal to noise ratio is called figure of merit.

22. What is the Purpose of re-emphasis and de-emphasis in FM?

The PSD of noise at the output of FM receiver sally increases rapidly at high frequencies but the PSD of message signal falls off at higher frequencies. This means the message signal doesn't utilize the frequency band in efficient manner. Such more efficient use of frequency band and improved noise performance can be obtained with the help of re-emphasis and deemphasis.

23. What are extended threshold demodulators?

Threshold extension s also called threshold reduction. It is achieved with the help of FMFB demodulator. In the local oscillator is replaced by voltage controlled oscillator (VCO).The VC frequency changes as per low frequency variations of demodulated signal. Thus the receiver responds only to narrow band of noise centered around instantaneous carrier frequency. This reduces the threshold of FMFB receiver.

24. What is threshold effect with respect to noise?

When the carrier to noise ratio reduces below certain value, the message information is lost. The performance of the envelope detector deteriorates rapidly and it has no proportion with carrier to noise ratio. This is called threshold effect.

Define pre-emphasis and de-emphasis.

Pre-emphasis:

It artificially emphasizes the high frequency components before modulation. This equalizes the low frequency and high frequency portions of the PSD and complete band is occupied.

De-emphasis:

This circuit attenuates the high frequency components. The attenuation characteristic is exactly opposite to that of pre-emphasis circuit. De-emphasis restores the power distribution of the original signal. The signal to noise ratio is improved because of pre-emphasis and de-emphasis circuits.

Define superheterodyne principle.

It can be defined as the process of operation of modulated waves to obtain similarly modulated waves of different frequency. This process uses a locally generated carrier wave, which determines the change of frequency.

27. Define signal to noise ratio.

Signal to noise ratio is the ratio of signal power to the noise power at the same point in a system.

28. What is threshold effect in an envelope detector? Explain.

When a noise is large compared to the signal at the input of the envelope detector, the detected output has a message signal completely mingled with noise. It means that if the input SNR is below a certain level, called threshold level, the noise dominates over the message signal, threshold is defined as value of the input signal to noise ratio (S_o/N_o) below which the output signal to noise ratio (S_i/N_i) deteriorates much more rapidly than the input signal to noise ratio. The threshold effect in an envelope detector whenever the carrier power-to-noise power ratio approaches unity or less.

**UNIT-V
INFORMATION THEORY**

1. What is entropy?

Entropy is also called average information per message. It is the ratio of total information to number of messages. i.e., Entropy, $H = \text{Total information} / \text{Number of messages}$

2. What is channel redundancy?

Redundancy = $1 - \text{code efficiency}$ Redundancy should be as low as possible.

3. Name the two source coding techniques.

The source coding techniques are, a) prefix coding b) Shannon-fano coding c) Huffman coding

Write the expression for code efficiency in terms of entropy. Code

efficiency = $\text{Entropy}(H) / \text{Average code word length}(N)$

What is memory less source?

The alphabets emitted by memory less source do not depend upon previous alphabets. Every alphabet is independent. For example a character generated by keyboard represents memory less source.

Explain the significance of the entropy $H(X/Y)$ of a communication system where X is the transmitter and Y is the receiver.

⁰ $H(X/Y)$ is called conditional entropy. It represents uncertainty of X, on average, when Y is known.

¹ In other words $H(X/Y)$ is an average measure of uncertainty in X after Y is received.

² $H(X/Y)$ represents the information lost in the noisy channel.

7. What is prefix code?

In prefix code, no codeword is the prefix of any other codeword. It is variable length code. The binary digits (codewords) are assigned to the messages as per their probabilities of occurrence.

8. Define information rate.

Information rate(R) is represented in average number of bits of information per second. It is calculated as, $R = r H$ Information bits / sec

Calculate the entropy of source with a symbol set containing 64 symbols each with a probability $p_i = 1/64$.

Here, there are $M = 64$ equally likely symbols. Hence entropy of such source is given as, $H = \log_2 M = \log_2 64 = 6$ bits / symbols

State the channel coding theorem for a discrete memory less channel.

Statement of the theorem:

Given a source of M equally likely messages, with $M \gg 1$, which is generating information at a rate. Given channel with capacity C . Then if, $R \leq C$ There exists a coding technique such that the output of the source may be transmitted over the channel with a probability of error in the received message which may be made arbitrarily small.

Explanation:

This theorem says that if $R \leq C$; it is possible to transmit information without any error even if noise is present. Coding techniques are used to detect and correct the errors.

11. What is information theory?

Information theory deals with the mathematical modeling and analysis of a communication system rather than with physical sources and physical channels

12. Explain Shannon-Fano coding.

An efficient code can be obtained by the following simple procedure, known as Shannon – Fano algorithm.

Step 1: List the source symbols in order of decreasing probability.

Step 2: Partition the set into two sets that are as close to equiprobable as possible, and sign 0 to the upper set and 1 to the lower set.

Step 3: Continue this process, each time partitioning the sets with as nearly equal probabilities as possible until further partitioning is not possible.

13. Define bandwidth efficiency.

The ratio of channel capacity to bandwidth is called bandwidth efficiency. i.e, Bandwidth efficiency = Channel Capacity/ Bandwidth (B).

14. Define channel capacity of the discrete memory less channel.

The channel capacity of the discrete memory less channel is given as maximum average mutual information. The maximization is taken with respect to input probabilities.

15. Define Huffman coding.

Procedure for Huffman Algorithm:

Create a leaf node for each symbol algorithm works from leaves to the root in the opposite direction and add it to frequency of occurrence.

While there is more than one node in the queue:

- ⁰ Remove the two nodes of lowest probability or frequency from the queue
- ¹ Prepend 0 and 1 respectively to any code already assigned to these nodes
- ² Create a new internal node with these two nodes as children and with probability equal to the sum of the two nodes' probabilities.
- ³ Add the new node to the queue.

The remaining node is the root node and the tree is complete.

16 MARK QUESTIONS
UNIT 1
AMPLITUDE MODULATION

Explain the generation of AM signals using Square Law Modulator.

Explain the detection of AM signals using Envelope Detector.

Explain about balanced modulator to generate DSB-SC signal.

Discuss about coherent detector to detect SSB-SC signal

Explain about the generation of SSB using Balanced Modulator.

Draw the circuit diagram of Ring Modulator and explain with its operation?

Discuss the coherent detection of DSB-SC modulated wave with a block diagram of detector and explain.

Draw the block diagram for the generation and demodulation of a VSB signal and explain the principle of operation.

Write short notes of frequency translation and FDM?

Explain the method of generating AM waves using linear time invariant circuits.

Explain the method of generating AM waves using Non-Linear circuits.

UNIT 2
ANGLE MODULATION

Explain the indirect method of generation of FM wave and any one method of demodulating an FM wave.

Discuss the indirect methods of generating a wide-band FM signal.
Draw the circuit diagram of Foster-seeley discriminator and explain its working.
Derive an expression for single tone FM wave and Narrowband FM wave?
Discuss the working FM using Armstrong method.
Explain FM stereo multiplexing?

UNIT 3

RANDOM PROCESS

Discuss about Central limit theorem in detail.
Explain in detail about Ergodic process.
Explain in detail about Random process and its Random variables.
Write short notes on covariance function.
Write short notes on Auto correlation function.
With neat diagram Linear filtering of Random process?

UNIT 4

NOISE CHARACTERIZATION

Discuss the noise performance of AM system using envelope detection.
Compare the noise performance of AM and FM systems.
Explain the significance of pre-emphasis and de-emphasis in FM systems.
Derive the noise power spectral density of the FM demodulation and explain its performance with diagram.
Explain the FM threshold effect and capture effect in FM?
Draw the block diagram of a superheterodyne receiver and explain the function of each block.
Explain the characteristics of superheterodyne receiver.
What is noise temperature? Deduce the expression for effective noise temperature for a Cascaded.
What is narrowband noise discuss the properties of the Quadrature components of a narrowband noise.
Derive the noise figure for cascade stages.
Define noise and explain the types of noise

UNIT 5

INFORMATION THEORY

Discuss source coding theorem, give the advantage and disadvantages of channel coding in detail, and discuss the data compaction.
Explain in detail Huffman coding algorithm and compare this with the other types of coding.

Explain the properties of entropy and with suitable example, explain the entropy of binary memory less source.

Define mutual information. Find the relation between the mutual information and the Joint entropy of the channel input and channel output. Explain the important properties of mutual information.

Encode the source symbols with following set of probabilities using Huffman coding.

ELECTROMAGNETIC FIELDS

UNIT I
STATIC ELECTRIC FIELDS
PART A

1. State stokes theorem.

The line integral of a vector around a closed path is equal to the surface integral of the normal component of its curl over any surface bounded by the path

$$\oint \mathbf{H} \cdot d\mathbf{l} = (\nabla \times \mathbf{H}) \cdot d\mathbf{s}$$

2. Define divergence.

The divergence of a vector \mathbf{F} at any point is defined as the limit of its surface integral per unit volume as the volume enclosed by the surface around the point shrinks to zero.

3. State Divergence Theorem.

The integral of the divergence of a vector over a volume v is equal to the surface integral of the normal component of the vector over the surface bounded by the volume.

4. What is the physical significance of div \mathbf{D} ?

$$\nabla \cdot \mathbf{D} = \rho_v$$

The divergence of a vector flux density is electric flux per unit volume leaving a small volume. This is equal to the volume charge density.

State the condition for the vector \mathbf{F} to be solenoidal.

$$\nabla \cdot \mathbf{F} = 0$$

State the condition for the vector \mathbf{F} to be irrotational.

$$\nabla \times \mathbf{F} = 0$$

Describe what are the sources of electric field and magnetic field?

Stationary charges produce electric field that are constant in time, hence the term electrostatics. Moving charges produce magnetic fields hence the term magnetostatics.

8. State coulombs law.

Coulombs law states that the force between any two point charges is directly proportional to the product of their magnitudes and inversely proportional to the square of the distance between them. It is directed along the line joining the two charges.

$$F = \frac{Q_1 Q_2}{4 \pi \epsilon r^2}$$

9. Define potential difference.

Potential difference is defined as the work done in moving a unit positive charge from one point to another point in an electric field.

10. Define potential.

Potential at any point is defined as the work done in moving a unit positive charge from infinity to that point in an electric field.

$$V = Q / 4 \pi \epsilon r$$

11. State the principle of superposition of fields.

The total electric field at a point is the algebraic sum of the individual electric field at that point.

12. What is a point charge?

Point charge is one whose maximum dimension is very small in comparison with any other length.

Define linear charge density. It is the charge per unit length.

Define surface charge density. It is the charge per surface area.

Define Biot –Savart Law?

The magnetic flux density produced by a current element at any point in a magnetic field is proportional to the current element and inversely proportional to the square of the distance between them.

16. What is a Scalar quantity?

A Quantity which has magnitude only is called Scalar quantity. It is represented by length. EG: Temperature, Mass, Volume and Energy.

17. What is a Vector quantity?

A Quantity which has both magnitude and direction is called Vector quantity. It is graphically represented by a line with an arrow to show magnitude and direction. EG: Force, Velocity, and Acceleration

18. Define Unit Vector?

A Vector which has magnitude unity and defining the same direction as given vector.

Give the properties of Vectors.

⁰ Vector addition obeys commutative law $A + B = B + A$

¹ Vector addition obeys associative law $A + (B + C) = (A + B) + C$

² $-A$ is also a vector. It has same magnitude; its direction is 180° away from direction of A. $A - B = A + (-B)$

Define Scalar or Dot Product.

$A \cdot B = AB \cos \Phi$ $0 \leq \Phi \leq \Pi$ where $A = |A|$ and $B = |B|$ and Φ angle between two vectors. It is denoted as $A \cdot B$ It is the product of magnitudes of A and B and the cosine of the angle

between them.

21. Define Cross or Vector product.

It is denoted as $A \times B$. It is a vector whose magnitude is equal to the product of magnitudes of two vectors multiplied by the sine angle between them and direction perpendicular to plane containing A and B.

UNIT II STATIC MAGNETIC FIELD

1. State Gauss law for electric fields

The total electric flux passing through any closed surface is equal to the total charge enclosed by that surface.

2. Define electric flux.

The lines of electric force is electric flux.

3. Define electric flux density.

Electric flux density is defined as electric flux per unit area.

4. Define electric field intensity.

Electric field intensity is defined as the electric force per unit positive charge.

$$E = F/Q = Q/4 \pi \epsilon r^2 \text{ V/m}$$

5. Name few applications of Gauss law in electrostatics.

Gauss law is applied to find the electric field intensity from a closed surface. e.g. Electric field can be determined for shell, two concentric shell or cylinders

6. State Gauss law for magnetic field.

The total magnetic flux passing through any closed surface is equal to zero. $\oint B \cdot ds = 0$

Give the expression for electric field intensity due to a single shell of charge E

$$= Q / 4 \pi \epsilon r^2$$

Give the expression for potential between two spherical shells

$$V = 1/4 \pi \epsilon (Q1/a - Q2/b)$$

Give the relationship between potential gradient and electric field.

$$E = - \nabla V$$

What is electrostatic force?

The force between any two particles due to existing charges is known as electrostatic force, repulsive for like and attractive for unlike.

11. What are dielectrics?

Dielectrics are materials that may not conduct electricity through it but on applying electric field induced charges are produced on its faces. The valence electrons in atoms of a dielectric are tightly bound to their nucleus.

12. What is a capacitor?

A capacitor is an electrical device composed of two conductors which are separated through a dielectric medium and which can store equal and opposite charges, independent of whether other conductors in the system are charged or not.

13. Define dielectric strength.

The dielectric strength of a dielectric is defined as the maximum value of electric field that can be applied to the dielectric without its electric breakdown.

14. What meaning would you give to the capacitance of a single conductor?

A single conductor also possess capacitance. It is a capacitor whose one plate is at infinity.

15. Why water has much greater dielectric constant than mica?

Water has a much greater dielectric constant than mica, because water has a permanent dipole moment, while mica does not have.

Write down the expression for capacitance between two parallel plates.

$$C = \epsilon A / d$$

What is meant by displacement current?

Displacement current is nothing but the current flowing through capacitor.

$$J = D / t$$

Write the boundary conditions at the interface between two perfect dielectrics.

i) The tangential component of electric field is continuous

$$\text{i.e) } E_{t1} = E_{t2}$$

ii) The normal component of electric flux density is continuous

$$\text{i.e) } D_{n1} = D_{n2}$$

19. Explain the conservative property of electric field.

The work done in moving a point charge around a closed path in a electric field is zero. Such a field is said to be conservative.

$$E \cdot dl = 0$$

20. What are equipotential surfaces?

An equipotential surface is a surface in which the potential energy at every point is of the same vale.

UNIT III

ELECTRIC AND MAGNETIC FIELDS IN MATERIALS

1. Write poisson's and laplace 's equations.

Poisson 's eqn:

$$\nabla^2 V = - \rho_v / \epsilon$$

Laplace' s eqn:

$$\nabla^2 V = 0$$

What are the significant physical differences between Poisson 's and laplace 's equations.

Poisson 's and laplace 's equations are useful for determining the electrostatic potential V in regions whose boundaries are known. When the region of interest contains charges poissons equation can be used to find the potential. When the region is free from charge laplace equation is used to find the potential.

3. Define magnetic field strength.

The magnetic field strength (H) is a vector having the same direction as magnetic flux density.

$$H = B/\mu$$

Write down the expression for magnetic field at the centre of the circular coil. H

$$= I/2a.$$

Write the expression for field intensity due to a toroid carrying a filamentary current I $H = NI / 2\pi R$

Give the relation between magnetic flux density and magnetic field intensity. B

$$= \mu H$$

Define inductance.

The inductance of a conductor is defined as the ratio of the linking magnetic flux to the current producing the flux. $L = N\phi / I$

Give the formula to find the force between two parallel current carrying conductors.

$$F = \mu I_1 I_2 / 2\pi R$$

Give the expression for torque experienced by a current carrying loop situated in a magnetic field.

$$T = I A B \sin\theta$$

10. What is torque on a solenoid?

$$T = N I A B \sin\theta$$

Write the expression for energy density in electrostatic field.

$$W = 1/2 \epsilon E^2$$

What is the expression for energy stored in a magnetic field? W

$$= 1/2 LI^2$$

What is energy density in magnetic field?

$$W = 1/2 \mu H^2$$

14. Distinguish between solenoid and toroid.

Solenoid is a cylindrically shaped coil consisting of a large number of closely spaced turns of insulated wire wound usually on a non magnetic frame. If a long slender solenoid is bent into the form of a ring and thereby closed on itself it becomes a toroid.

15. What is Lorentz force?

Lorentz force is the force experienced by the test charge. It is maximum if the direction of movement of charge is perpendicular to the orientation of field lines.

16. State Biot –Savarts law.

It states that the magnetic flux density at any point due to current element is proportional to

the current element and sine of the angle between the elemental length and inversely proportional to the square of the distance between them

$$dB = \mu I dl \sin\theta / 4\pi r^2$$

17. State amperes circuital law.

Magnetic field intensity around a closed path is equal to the current enclosed by the path. $\oint H \cdot dl = I$

Give the force on a current element.

$$dF = B I dl \sin\theta$$

Define magnetic vector potential.

It is defined as that quantity whose curl gives the magnetic flux density.

$$B = \nabla \times A = \mu / 4\pi \int r dv \text{ web/m}^2$$

20. Define magnetic moment.

Magnetic moment is defined as the maximum torque per magnetic induction of flux density.

$$m = IA$$

Give the relation between electric field intensity and electric flux density.

$$D = E\epsilon \text{ C/m}^2$$

Define current density.

Current density is defined as the current per unit area.

$$J = I/A \text{ Amp/m}^2$$

23. Define self inductance.

Self inductance is defined as the rate of total magnetic flux linkage to the current through the coil.

24. Define magnetic moment.

Magnetic moment is defined as the maximum torque on the loop per unit magnetic induction.

Write the point form of continuity equation and explain its significance.

$$\nabla \cdot J = - \rho_v / \epsilon$$

State point form of ohms law.

Point form of ohms law states that the field strength within a conductor is proportional to the current density.

$$J = \zeta E$$

27. Write down the magnetic boundary conditions.

The normal components of flux density B is continuous across the boundary.

The tangential component of field intensity is continuous across the boundary.

UNIT IV
TIME VARYING ELECTRIC AND MAGNETIC FIELDS

1. State Maxwell's fourth equation.

The net magnetic flux emerging through any closed surface is zero.

2. State Maxwell's Third equation

The total electric displacement through the surface enclosing a volume is equal to the total charge within the volume.

3. Define ohms law at a point

Ohms law at a point states that the field strength within a conductor is proportional to current density.

4. State electric displacement.

The electric flux or electric displacement through a closed surface is equal to the charge enclosed by the surface.

5. What is displacement flux density?

The electric displacement per unit area is known as electric displacement density or electric flux density.

6. What is the significance of displacement current?

The concept of displacement current was introduced to justify the production of magnetic field in empty space. It signifies that a changing electric field induces a magnetic field. In empty space the conduction current is zero and the magnetic fields are entirely due to displacement current.

7. State Poyntings Theorem.

The net power flowing out of a given volume is equal to the time rate of decrease of the the energy stored within the volume- conduction losses.

8. Define poynting vector.

The vector product of electric field intensity and magnetic field intensity at a point is a measure of the rate of energy flow per unit area at that point. $P = E \times H$

9. What is an emf?

An electro-motive force is a voltage that arises from conductors moving in a magnetic field or from changing magnetic fields.

10. State Faraday's law.

Faraday's law states that, the total emf induced in a closed circuit is equal to the time rate of decrease of the total magnetic flux linking the circuit.

$$\frac{e}{dt} = - \frac{d\phi}{dt} \quad \text{V}$$

11. State Lenz's law.

The Lenz's law states that, the induced current in the loop is always in such a direction as to

produce flux opposing the change in flux density.

Explain briefly the different types of emf’s produced in a conductor placed in a magnetic field.

There are two ways in which we can induce emf in a conductor. If a moving conductor is placed in a static magnetic field then the emf produced in the conductor is called dynamically induced emf. If the stationary conductor is placed in a time varying magnetic field, then the emf produced is called statically induced emf.

Give the Maxwell’s equation – I point form.

Maxwell’s equation – I is derived from the Ampere’s circuital law which states that the line integral of magnetic field intensity H on any closed path is equal to the current enclosed by that path.

$$\oint H \cdot dl = I$$

Maxwell’s equation – I in point form is

$$\nabla \times H = \sigma E + \epsilon \frac{\partial E}{\partial t}$$

The magneto motive force around a closed path is equal to the sum of the conduction current and displacement current enclosed by the path.

14. What is Eddy current and Eddy current loss?

In electrical machines, the alternating magnetic fields induce emf in the cores also apart from the coil. This small amount of emf induced in the core circulates current in the core. This current is called eddy current and the power loss, which appears in the form of heat, due to these eddy currents is called eddy current loss.

15. What is main cause of eddy current?

The main cause of eddy current is that it produces ohmic power loss and causes local heating.

16. Give the Maxwell’s equation – III in both integral form and point form.

The Maxwell’s equation – III is derived from electric Gauss’s law which states that the electric flux through any closed surface is equal to the charge enclosed by the surface.

$$= Q$$

Maxwell’s equation – III in integral form is

$$\oint_S D \cdot ds = \iiint_V \rho dv$$

Maxwell’s equation – III in point form is

$$\nabla \cdot D = \rho$$

The total electric displacement through the surface enclosing a volume is equal to the total charge within the volume.

17. Give the Maxwell's equation – IV in integral form.

Maxwell's equation – IV is derived from magnetic Gauss's law which states that, the total magnetic flux through any closed surface is equal to zero.

$$= 0$$

Maxwell's equation – IV in integral form is

$$\oint_s B \cdot ds = 0$$

Give the Maxwell's equation – IV in point form.

Maxwell's equation – IV in point form is

$$\nabla \cdot B = 0$$

The net magnetic flux emerging through any closed surface is zero.

19. Distinguish between the conduction current and displacement current.

Conduction current I_c is flowing through a conductor having resistance R , when potential V is applied across the conductor.

$$I_c = \frac{V}{R} \quad \text{A}$$

Displacement current I_D is flowing through a capacitor when ac voltage is applied across the capacitor.

$$I_D = C \frac{dV}{dt}$$

**UNIT V
ELECTROMAGNETIC WAVES**

1. Define a wave.

If a physical phenomenon that occurs at one place at a given time is reproduced at other places at later times, the time delay being proportional to the space separation from the first location

then the group of phenomena constitutes a wave.

2. Mention the properties of uniform plane wave.

At every point in space, the electric field E and magnetic field H are perpendicular to each other. The fields vary harmonically with time and at the same frequency everywhere in space.

3. Define intrinsic impedance or characteristic impedance.

It is the ratio of electric field to magnetic field (or) It is the ratio of square root of permeability to permittivity of medium.

Give the characteristic impedance of free space.

377ohms

Define skin depth

It is defined as that depth in which the wave has been attenuated to $1/e$ or approximately 37% of its original value

6. What is the effect of permittivity on the force between two charges?

Increase in permittivity of the medium tends to decrease the force between two charges and decrease in permittivity of the medium tends to increase the force between two charges.

7. Define loss tangent.

Loss tangent is the ratio of the magnitude of conduction current density to displacement current density of the medium.

8. Define reflection and transmission coefficients.

Reflection coefficient is defined as the ratio of the magnitude of the reflected field to that of the incident field.

9. Define transmission coefficients.

Transmission coefficient is defined as the ratio of the magnitude of the transmitted field to that of incident field.

10. How can the eddy current losses be eliminated?

The eddy current losses can be eliminated by providing laminations. It can be proved that the total eddy current power loss decreases as the number of laminations increases.

What is the fundamental difference between static electric and magnetic field lines? There is a fundamental difference between static electric and magnetic field lines. The tubes of electric flux originate and terminate on charges, whereas magnetic flux tubes are continuous.

What are uniform plane waves?

Electromagnetic waves which consist of electric and magnetic fields that are perpendicular to each other and to the direction of propagation and are uniform in plane perpendicular to the direction of propagation are known as uniform plane waves.

13. Write short notes on imperfect dielectrics.

A material is classified as an imperfect dielectrics when conduction current density is small in magnitude compared to the displacement current density.

14. What is the significant feature of wave propagation in an imperfect dielectric?

The only significant feature of wave propagation in an imperfect dielectric compared to that in a perfect dielectric is the attenuation undergone by the wave.

15. List out the properties of a uniform plane wave.

If the plane of wave is the same for all points on a plane surface, it is called plane wave. If the amplitude is also constant in a plane wave, it is called uniform plane wave. The properties of uniform plane waves are:

At every point in space, E and H are perpendicular to each other and to the direction of travel.

The fields vary with time at the same frequency, everywhere in space.

Each field has the same direction, magnitudes and phase at every point in any plane perpendicular to the direction of wave travel.

16. Give the expression for the characteristic impedance of the wave.

The characteristic impedance or intrinsic impedance is the ratio of the electric field intensity to the magnetic field intensity.

$$\frac{E}{H} = \sqrt{\frac{\mu}{\epsilon}}$$

where, μ is the permeability of the medium and ϵ is the permittivity of the medium.

17. What is Vector Helmholtz equation?

The wave equation in lossless medium in phasor form is called the vector Helmholtz equation.

$$\nabla^2 E + \mu\epsilon\omega^2 E = 0$$

20. Give the wave equation for a conducting medium.

The wave equation for a conducting medium in phasor form is

$$\nabla^2 E - j(\omega\mu\sigma + j\mu\epsilon\omega^2)E = 0$$

18. What is skin effect and skin depth?

In a good conductor the wave is attenuated as it progresses. At higher frequencies the rate of attenuation is very large, and the wave may penetrate only a very short distance before being reduced to a small value. This effect is called skin effect.

The skin depth (δ) is defined as that depth in which the wave has been attenuated to $1/e$ or approximately 37% of its original value. It is also known as depth of penetration.

Give the expression for the velocity of propagation of a wave in any medium.

The velocity of propagation of a wave in any medium is,

$$v = \frac{\omega}{\beta} = \frac{1}{\sqrt{\epsilon \mu}}$$

where ω is the angular velocity and β is the phase shift.

PART-B

UNIT I

State and prove divergence theorem.

State and prove stokes theorem

Explain the types of charge distributors?

Derive the formula for electric field intensity at a point due to 'n' number of point charges.

Derive electric field intensity at the given point due to line charge of infinite length.

Apply Gauss's law to an unsymmetrical field.

Apply Gauss's law to an infinite sheet of charge.

Apply Gauss's law to an infinite line charge.

Define dipole. Derive the electric field intensity, E and the potential due to a dipole.

Obtain the expression for energy density in an electrostatic field.

Derive electric field intensity at the given point due to line charge of finite length.

Point charge 1mC and -2mC are located at (3, 2,-1) and (-1,-1,4) respectively.

Calculate the electric force on a 10nC charge located at (0, 4,1) and electric field intensity at that point.

A circular ring of radius 'a' carries a uniform charge L C/m and is placed on the XY plane with the axis same as z axis. Find the electric field intensity.

Two point charges are located at points P1(-1, 0,0) and P2(1,0,0). The charge at P1 is 1C and the charge at P2 is -2 C. find the location on the X axis where a positive test charge will not experience any force. Distances are in meters.

UNIT II

Discuss the properties of dielectric materials.

Give and derive the expression for capacitance of coaxial cables with single and two dielectrics.

Derive the expression for capacitance of a charged sphere.

Derive the expression for Laplace equation

Obtain Poisson's equation from Gauss's law?

Discuss the properties and boundary conditions of dielectric materials.

Give and derive the expression for capacitance of coaxial cables with single and two dielectrics.

Derive the expression for capacitance of a two-wire line.

Write the expression for Laplace and Poisson's equation and derive it for various coordinate systems.

Deduce an expression for the joint capacitance of two capacitors, C1 and C2, (i) in series and (ii) in parallel. If C1 = 100 microfarad and C2 = 50 microfarad, calculate a) the joint capacitance and b) the total energy stored with a steady applied potential difference of 1000V.

In the case of a two concentric spherical shell capacitor, the radii of the two spheres differ by 4cm, and the capacitance of the spherical conductor is 53.33 Pico farad. If the outer sphere is earthed, calculate the radius, assuming air as dielectric.

Obtain the boundary conditions on the interface of a dielectric and a conductor.

Current density is given by $J = (1/r) e^{-t}$ ar A/m². At t = 1s, calculate total outward current in a cylinder if r = 5m and also find the velocity with which the J moves at arbitrary radius 'r' ('r' = radius of cylinder).

UNIT III

Calculate field using Ampere's Circuital law for infinitely long solenoid.

Determine the Magnetic flux density B caused by a finite length current filament of length ' L ' on the z -axis at a distance ' d ' from the origin.

Explain how to calculate field using Ampere's Circuital Law for symmetrical Current distribution for infinitely long filament carrying current I

Define and explain Vector Magnetic Potential.

A circular loop of radius ' b ' in the XY plane and carries a current ' I ', as depicted in figure. Obtain an expression for the magnetic flux density at a point on the positive z axis.

Calculate field using Ampere's Circuital law for infinitely long solenoid.

Determine the Magnetic flux density B caused by a finite length current filament of length ' L ' on the z -axis at a distance ' d ' from the origin.

Explain how to calculate field using Ampere's Circuital Law for symmetrical current distribution for infinitely long filament carrying current I

Explain how to calculate field using Ampere's Circuital Law for symmetrical current distribution for coaxial cable. a) state and explain ampere's Law b) A current filament of 5.0 A in the ay direction is parallel to the y axis at $x = 2\text{m}$, $z = -2\text{m}$. Find H at the origin.

Define and explain Vector Magnetic Potential.

Apply Ampere's Circuital Law to the perimeter of a differential surface element and obtain the point form of ampere's circuital Law.

UNIT IV

Give the Lorentz force equation and find the force on the differential current element.

Find the force and torque in a closed circuit.

Derive the magnetic boundary conditions.

Derive the expression for inductance and mutual inductance.

Obtain the expression for the energy stored in magnetic field and energy density.

Find the self-inductance of a solenoid.

Obtain the expression for the torque experienced by a differential rectangular current

l o o p lying in the magnetic field.

a) A conductor 4m long lies along the y-axis with a current of 10 A in the ay direction.

Find the force on the conductor if the field in the region is $B=0.05ax$ T.

⁰ A conductor of length 2.5m located at $z=0=4m$ carries a current of 12 A in the ay

direction. Find the uniform B in the region if the force on the conductor is $1.20*10^{-2}$ N in the direction $(ax + az)/2$.

Find the maximum torque on an 85 turn rectangular coil, 0.2m by 0.3m, carrying current of 2.0 A in a field $B = 6.5$ T.

Find the maximum torque on an arbitrary charged particle if the charge is $1.602*10^{-19}$ C, the circular path has a radius of $0.5*10^{-10}$ m, the angular velocity is $4.0*10^{16}$ rad/s and $B = 0.4*10^{-3}$ T.

Calculate the total torque produced by the loop of dimension 1m X 2m. One corner of the loop lies in the origin. A field $B_0 = -0.6ay + 0.8 az$ is distributed in the loop. The loop current is 4mA.

Find the magnetic flux density and field intensity at appoint P due to a straight conductor of length 'l' carrying current I.

Obtain the expression for the torque experienced by a differential rectangular current loop lying in the magnetic field.

An air core toroid has 500 turns, a cross sectional area of 6cm², a mean radius of 15cm and a coil current of 4A. Calculate magnetic field intensity. Check your answer by applying Ampere's circuital law.

UNIT V

Derive Maxwell's equation for steady fields in point form and integral form.

Compare circuit and field theory in detail.

Derive the wave equation.

Explain the inconsistency in Ampere's circuital law.

Explain the displacement current density.

Derive point and integral forms of Poynting theorem.

Derive Maxwell's equations in point and integral forms for time varying fields.

Derive the wave equation in phasor form.

A circular loop conductor lies in plane $z = 0$ and has a radius of 0.1m and resistance of 5 ohms. Given $B = 0.2 \sin 103t \hat{a}_z$, determine current in the loop.

Explain the inconsistency in Ampere's circuital law.

LINEAR INTEGRATED CIRCUITS

UNIT I

IC FABRICATION AND CIRCUIT CONFIGURATION FOR LINEAR IC'S

What are the advantages of ICs over discrete circuits?

- 0 Minimization & hence increased equipment density.
- 1 Cost reduction due to batch processing.
- 2 Increased system reliability
- 3 Improved functional performance.
- 4 Matched devices.
- 5 Increased operating speeds
- 6 Reduction in power consumption

What are the popular IC packages available?

- Metal can package.
- Dual-in-line package.
- Ceramic flat package.

3. What is OPAMP?

An operational amplifier is a direct coupled high gain amplifier consisting of one or more differential amplifiers, followed by a level translator and an output stage. It is a versatile device that can be used to amplify ac as well as dc input signals & designed for computing mathematical functions such as addition, subtraction, multiplication, integration & differentiation. The operational amplifier is a multi terminal device which is used to perform various mathematical operations such as addition, subtraction, multiplication, integration & differentiation.

4. Draw the pin configuration of IC741.

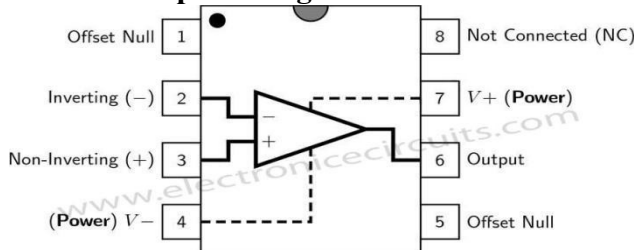

List out the ideal characteristics of OPAMP.

- 0 Open loop gain infinite
- 1 Input impedance infinite
- 2 Output impedance low
- 3 Bandwidth infinite
- 4 Zero offset, ie, $V_o=0$ when $V_1=V_2=0$

What are the different kinds of packages of IC741?

- 0 Metal can (TO) package

¹ Dual-in-line package

² Flat package or flat pack

Define integrated circuits.

A packaged electronic circuit in which millions of discrete components are fabricated on a single silicon chip of the order of one square centimeter, to perform the complete function is called an integrated circuit.

8. What is differential amplifier?

The differential amplifier is basically a voltage amplifier which amplifies the difference between the two input voltage signals.

9. Mention differential gain and common mode gain.

The A_d is the gain with which differential amplifier amplifies the difference between two input signals. Hence it is called differential gain of the differential amplifier.

A_d = differential gain

$$V_o = A_d V_d$$

$$A_d = V_o/V_d$$

The average level of two input signals is called common mode signal denoted as V_c .

$V_c = (V_1 + V_2)/2$ The gain with which it amplifies the common mode signal to produce the output is called common mode gain of the differential amplifier denoted as A_c . $V_o = A_c V_c$

10. Define CMRR of an op-amp.

The relative sensitivity of an op-amp to a difference signal as compared to a common –mode signal is called the common –mode rejection ratio. It is expressed in decibels. $CMRR = A_d/A_c$

11. What are the features of differential amplifiers?

The various features of a differential amplifier are high differential voltage gain, low common mode gain, high CMRR, two input terminals, high input impedance, large bandwidth, low offset voltages and current, low output impedance.

12. Mention the methods to improve the CMRR.

To improve the CMRR, the common mode gain A_c must be reduced and A_d must be increased. So as to reduce A_c the following methods are used.

Constant current bias method and

Use of current mirror circuits

The other method used to increase A_d to improve CMRR is called use of an active load.

13. What are the applications of current sources?

Transistor current sources are widely used in analog ICs both as biasing elements and as load devices for amplifier stages.

14. What is current mirror?

The circuit in which the output current is forced to equal to the input is called current mirror circuit. In a current mirror circuit, the output current is the mirror image of the input current.

15. What is voltage reference circuit?

A voltage reference circuit is constant dc voltage source which acts as a reference or standard for other circuits and is independent of changes in the parameters like temperatures, line voltages, load current etc.

Justify the reasons for using current sources in integrated circuits.

- ⁰ Superior insensitivity of circuit performance to power supply variations and temperature.
- ¹ More economical than resistors in terms of die area required providing bias currents of small value.
- ² When used as load element, the high incremental resistance of current source results in high voltage gains at low supply voltages.

What is the advantage of widlar current source over constant current source?

Using constant current source output current of small magnitude (micro amp range) is not attainable due to the limitations in chip area. Widlar current source is useful for obtaining small output currents. Sensitivity of widlar current source is less compared to constant current source.

Mention the advantages of Wilson current source.

- ⁰ Provides high output resistance.
- ¹ Offers low sensitivity to transistor base currents.

Define sensitivity.

Sensitivity is defined as the percentage or fractional change in output current per percentage or fractional change in power-supply voltage.

20. What are the limitations in a temperature compensated zener-reference source?

A power supply voltage of atleast 7 to 10 V is required to place the diode in the breakdown region and that substantial noise is introduced in the circuit by the avalanching diode.

21. What do you mean by a band-gap referenced biasing circuit?

The biasing sources referenced to V_{BE} have a negative temperature co-efficient and V_T has a positive temperature co-efficient. Band gap reference circuit is one in which the output current is referenced to a composite voltage that is a weighted sum of V_{BE} and V_T so that by proper weighting, zero temperature co-efficient can be achieved.

22. In practical op-amps, what is the effect of high frequency on its performance?

The open-loop gain of op-amp decreases at higher frequencies due to the presence of parasitic capacitance. The closed-loop gain increases at higher frequencies and leads to instability.

What are the assumptions made from ideal opamp characteristics?

- ⁰ The current drawn by either of the input terminals (non-inverting/inverting) is negligible.
- ¹ The potential difference between the inverting & non-inverting input terminals is zero.

24. Mention some of the linear applications of op – amps.

Adder, subtractor, voltage –to- current converter, current –to- voltage converters, instrumentation amplifier, analog computation, power amplifier, etc are some of the linear op-amp circuits.

25. Mention some of the non – linear applications of op-amps:-

Rectifier, peak detector, clipper, clamper, sample and hold circuit, log amplifier, anti –log amplifier, multiplier are some of the non – linear op-amp circuits.

What are the areas of application of non-linear op- amp circuits?

- 0 Industrial instrumentation
- 1 Communication
- 2 Signal processing

What happens when the common terminal of V+ and V- sources is not grounded?

If the common point of the two supplies is not grounded, twice the supply voltage will get applied and it may damage the op-amp.

28. Define input offset voltage.

A small voltage applied to the input terminals to make the output voltage as zero when the two input terminals are grounded is called input offset voltage.

Define input offset current. State the reasons for the offset currents at the input of the op-amp.

The difference between the bias currents at the input terminals of the op-amp is called as input offset current. The input terminals conduct a small value of dc current to bias the input transistors. Since the input transistors cannot be made identical, there exists a difference in bias currents.

In practical op-amps, what is the effect of high frequency on its performance?

The open-loop gain of op-amp decreases at higher frequencies due to the presence of parasitic capacitance. The closed-loop gain increases at higher frequencies and leads to instability.

31. What is the need for frequency compensation in practical op-amps?

Frequency compensation is needed when large bandwidth and lower closed loop gain is desired. Compensating networks are used to control the phase shift and hence to improve the stability.

Mention the frequency compensation methods.

- 0 Dominant-pole compensation
- 1 Pole-zero compensation.

What are the merits and demerits of Dominant-pole compensation?

- 0 Noise immunity of the system is improved.
- 1 Open-loop bandwidth is reduced.

Define slew rate.

The slew rate is defined as the maximum rate of change of output voltage caused by a step input voltage. An ideal slew rate is infinite which means that op-amp's output voltage should change instantaneously in response to input step voltage.

35. Why IC 741 is not used for high frequency applications?

IC741 has a low slew rate because of the predominance of capacitance present in the circuit at higher frequencies. As frequency increases the output gets distorted due to limited slew rate.

36. What causes slew rate?

There is a capacitor with-in or outside of an op-amp to prevent oscillation. It is this capacitor which prevents the output voltage from responding immediately to a fast changing input.

37. Define thermal drift.

The bias current, offset current & offset voltage change with temperature. A circuit carefully nulled at 25oC may not remain so when the temperature raises to 35oC. This is called thermal drift. Often, offset current drift is expressed in nA/ °C and offset voltage drift in mV/ °C.

38. Define supply voltage rejection ratio(SVRR).

The change in OPAMP's input offset voltage due to variations in supply voltage is called the supply voltage rejection ratio. It is also called Power Supply Rejection ratio (PSRR) or Power Supply Sensitivity (PSS).

39. What is current mirror?

The circuit in which the output current is forced to equal the input current is called current mirror

40. What is active load? Why it is used in the differential amplifier?

The current mirror circuit is used as a collector load resistance is called an active load. This circuit provides high value of a.c. collector resistance which is required to achieve high differential gain but it does not disturb d.c. conditions of the circuit. The quiescent voltage required across the current mirror is a fraction of the supply stage. This eliminates the need for high biasing supply voltages. Due to all these advantages, active load is used in the differential amplifier circuit.

41. What is a voltage reference circuit?

A voltage reference circuit is a constant d.c. voltage source which acts as a reference or standard for other circuits and is independent of changes in parameters like temperature, line voltage, load current etc.

What are the AC characteristics of an op-amp?

- ⁰ Frequency response.
- ¹ Slew rate.

What are the DC characteristics of an op-amp? Give typical values for an IC741?

- ⁰ Input bias current: 500nA.
- ¹ Input offset current: 200nA.
- ² Input offset voltage: 6mV

Thermal drift.

UNIT II

Applications of Op Amp

1. Mention some of the linear applications of op – amps.

Adder, subtractor, voltage –to- current converter, current –to- voltage converters, instrumentation amplifier, analog computation, power amplifier, etc are some of the linear op-amp circuits.

2. Mention some of the non – linear applications of op-amps.

Rectifier, peak detector, clipper, clamper, sample and hold circuit, log amplifier, anti –log amplifier, multiplier are some of the non – linear op-amp circuits.

What are the areas of application of non-linear op- amp circuits?

- 0 Industrial instrumentation
- 1 Communication
- 2 Signal processing

Define Sign Changer.

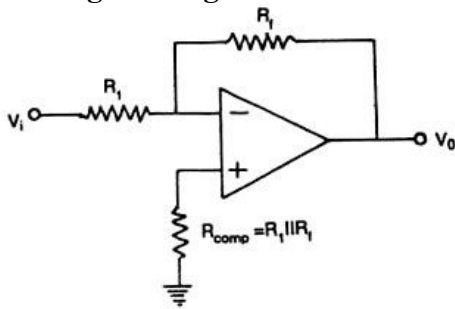

If the resistors in inverting amplifier are equal then the output is 180° out of phase with respect to input. This circuit is called as sign changer.

5. Define Scale changer.

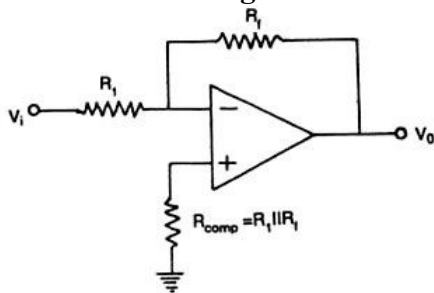

If the resistors in inverting amplifier is different then the output is multiplied by the factor $k = R_f/R_1$ with input voltage. This circuit is called as scale changer.

6. What are phase shift circuits?

A phase shifter circuit is one in which all signals are transmitted from input to output without change in amplitude but the circuit introduces a phase shift as signal transmits from input to output.

7. What is voltage follower?

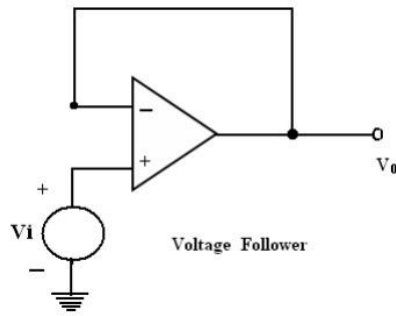

Voltage follower is circuit in which the output voltage follows the input voltage without any change both in magnitude and phase.

8. Define summer.

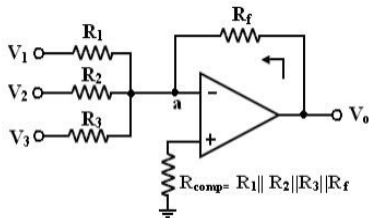

Op-amp may be used to design a circuit whose output is the sum of several input signals. Such a circuit is called a summing amplifier or a summer.

9. Define subtractor or difference amplifier.

Subtractor is a circuit whose output is the difference of the input signal. Such circuit is called as subtractor or difference amplifier.

10. What is the need for an instrumentation amplifier?

In a number of industrial and consumer applications, the measurement of physical quantities is usually done with the help of transducers. The output of transducer has to be amplified so that it can drive the indicator or display system. This function is performed by an instrumentation amplifier.

List the features of instrumentation amplifier:

- 0 high gain accuracy
- 1 high CMRR
- 2 high gain stability with low temperature co-efficient
- 3 low dc offset
- 4 low output impedance

List the applications of Log amplifiers:

*Analog computation may require functions such as $\ln x$, $\log x$, $\sin hx$ etc. These functions can be performed by log amplifiers.

Log amplifier can perform direct dB display on digital voltmeter and spectrum analyzer.

Log amplifier can be used to compress the dynamic range of a signal

13. What are the limitations of the basic differentiator circuit?

*At high frequency, a differentiator may become unstable and break into oscillations

*The input impedance decreases with increase in frequency, thereby making the circuit sensitive to high frequency noise.

14. Write down the condition for good differentiation.

For good differentiation, the time period of the input signal must be greater than or equal to $R_f C_f$. $T > R_f C_f$ Where, R_f is the feedback resistance C_f is the input capacitance.

15. Define integrator.

An integrator is a circuit which produces the output as integration of input voltage.

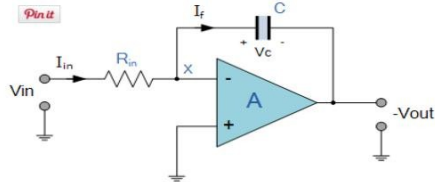

$$V_o = \frac{-1}{R_f C_f} \int V_{in} dt$$

16. Define differentiator.

A differentiator is a circuit which produces the output as differentiation of input signal.

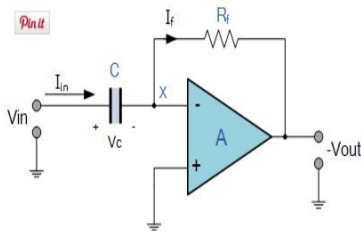

$$V_{OUT} = -R_F C \frac{dV_{IN}}{dt}$$

17. What is a comparator?

A comparator is a circuit which compares a signal voltage applied at one input of an op-amp with a known reference voltage at the other input. It is an open loop op - amp with output + Vsat

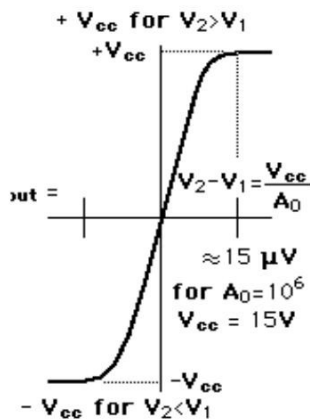
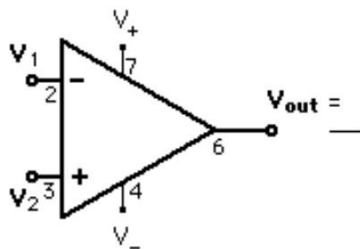

What are the applications of comparator?

- 0 Zero crossing detector
- 1 Window detector
- 2 Time marker generator
- 3 Phase detector

19. What is a Schmitt trigger?

Schmitt trigger is a regenerative comparator. It converts sinusoidal input into a square wave output. The output of Schmitt trigger swings between upper and lower threshold voltages, which are the reference voltages of the input waveform.

What are the applications of V-I converter?

- 0 Low voltage dc and ac voltmeter
- 1 LED
- 2 Zener diode tester

What do you mean by a precision diode?

The major limitation of ordinary diode is that it cannot rectify voltages below the cut – in voltage of the diode. A circuit designed by placing a diode in the feedback loop of an op – amp is called the precision diode and it is capable of rectifying input signals of the order of mill volt.

Write down the applications of precision diode.

- 0 Half - wave rectifier
- 1 Full - Wave rectifier
- 2 Peak – value detector
- 3 Clipper
- 4 Clamper

What are the different types of filters?

- *Based on functions: Low pass filter, High pass filter, Band pass filter, Band reject filter
- *Based on order of transfer function: first, second, third higher order filters.
- *Based on configuration: Bessel, Chebychev, Butterworth filters.

24. Define Peak detector.

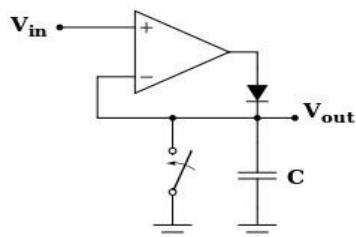

An op amp circuit which used to detect peak values is called peak detector.

25. Define Clipper.

In op-amp clipper circuits a rectifier diode may be used to clip off a certain portion of the input signal to obtain a desired o/p waveform. The diode works as an ideal diode (switch) because when on the voltage drop across the diode is divided by the open loop gain of the op-amp. When off (reverse biased) the diode is an open circuit.

26. Define Clamper.

In an op-amp clamper circuits, however a predetermined dc level is deliberately inserted in the o/p volt. For this reason, the clamper is sometimes called a dc inverter.

27. What is a filter?

Filter is a frequency selective circuit that passes signal of specified band of frequencies and attenuates the signals of frequencies outside the band

28. What are the demerits of passive filters?

Passive filters works well for high frequencies. But at audio frequencies, the inductors become problematic, as they become large, heavy and expensive. For low frequency applications, more number of turns of wire must be used which in turn adds to the series resistance degrading inductor's performance ie, low Q, resulting in high power dissipation.

29. What are the advantages of active filters over the passive filters?

Active filters use amplifying elements, especially op amps, with resistors and capacitors in their feedback loops, to synthesize the desired filter characteristics. Active filters can have high input impedance, low output impedance, and virtually any arbitrary gain.

They are also usually easier to design than passive filters. Possibly their most important attribute is that they lack inductors, thereby reducing the problems associated with those components.

30. What are the advantages of active filters?

Active filters used op- amp as the active element and resistors and capacitors as passive elements.

By enclosing a capacitor in the feed back loop, inductor less active filters can be obtained Op-amp used in non – inverting configuration offers high input impedance and low output impedance, thus improving the load drive capacity.

Mention some commonly used as active filters.

- 0 Low pass filter
- 1 High pass filter
- 2 Band pass filter
- 3 Band reject filter.

Draw the frequency response of LPF, HPF, BPF and BSF.

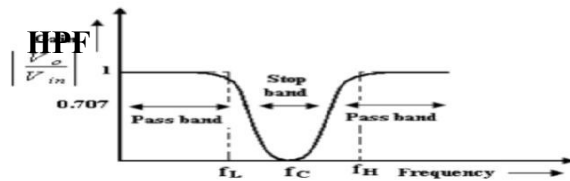
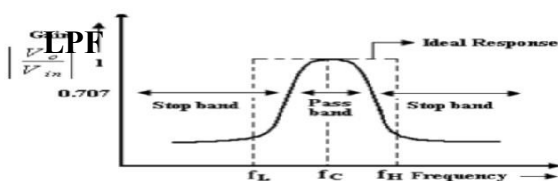
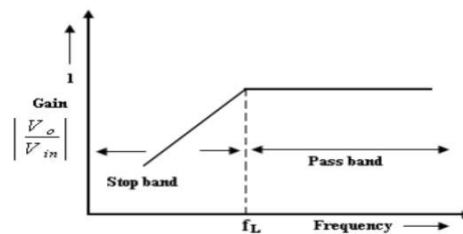
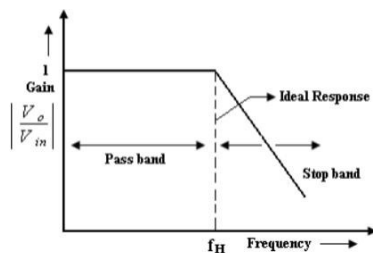

UNIT III

Analog Multiplier and PLL

1. Define multiplier.

The circuit which performs the multiplication of the two input voltages is called as multiplier circuit. Thus the output is proportional to the product of two analog inputs V1 and V2. Such multiplier circuits are used in the variety of applications such as squarer, square root extractor, frequency doubler etc.

Mention the applications of multiplier.

- ⁰ It is used for squaring and square root calculations.
- ¹ It is used to solve non linear equations.
- ² It is used for voltage follower, rms calculations, rectifier phase shift detection etc.
- ³ It is used in communication in amplitude modulation, phase modulation, frequency modulation.

Mention the multiplier techniques.

Logarithmic multipliers.	Logarithmic
Quarter square multipliers	Quarter square
Pulse width / height modulation multipliers	Pulse width / height
Transconductance multipliers.	Transconductance
Current rating multipliers.	Current rating

What are the advantages of variable transconductance technique?

Simple to integrate into monolithic chip.	Simple to integrate
Provides very good accuracy	Provides very good
Very cheap hence economical	Very cheap hence
Provides four quadrant operations.	Provides four

What is a Gilbert cell?

A circuit which uses emitter coupled pair in series with a cross coupled emitter coupled pairs is called a Gilbert cell.

What are the applications of Gilbert cell?

As a four quadrant linear multiplier which can be used as square and square root extractor, frequency doublers, RMS detector, phase angle detector etc.	As a four
As a balanced amplitude modulator in communication applications.	As a balanced

Applications	In switching
Automatic gain control amplifiers	In analog IC design
Mixers	Automatic gain
	Mixers

Mention some areas where PLL is widely used.

- 0 Radar synchronization
- 1 satellite communication systems
- 2 air borne navigational systems

3 FM communication systems

List the basic building blocks of PLL.

- 0 Phase detector/comparator
- 1 Low pass filter
- 2 Error amplifier
- 3 Voltage controlled oscillator

What are the three stages through which PLL operates?

- 0 Free running
- 1 Capture
- 2 Locked/ tracking

Define lock-in range of a PLL:

The range of frequencies over which the PLL can maintain lock with the incoming signal is called the lock-in range or tracking range. It is expressed as a percentage of the VCO free running frequency.

11. Define capture range of PLL:

The range of frequencies over which the PLL can acquire lock with an input signal is called the capture range. It is expressed as a percentage of the VCO free running frequency.

12. Define Pull-in time.

The total time taken by the PLL to establish lock is called pull-in time. It depends on the initial phase and frequency difference between the two signals as well as on the overall loop gain and loop filter characteristics.

For perfect lock, what should be the phase relation between the incoming signal and VCO output signal?

The VCO output should be 90 degrees out of phase with respect to the input signal.

Give the classification of phase detector:

- *Analog phase detector
- *Digital phase detector

15. What is a switch type phase detector?

An electronic switch is opened and closed by signal coming from VCO and the input signal is chopped at a repetition rate determined by the VCO frequency. This type of phase detector is called a half wave detector since the phase information for only one half of the input signal is detected and averaged.

16. What are the problems associated with switch type phase detector?

The output voltage V_e is proportional to the input signal amplitude. This is undesirable because it makes phase detector gain and loop gain dependent on the input signal amplitude.

17. What is a voltage controlled oscillator?

Voltage controlled oscillator is a free running multivibrator operating at a set frequency called the free running frequency. This frequency can be shifted to either side by applying a dc control voltage and the frequency deviation is proportional to the dc control voltage.

On what parameters does the free running frequency of VCO depend on?

- *External timing resistor, R_T
- *External timing capacitor, C_T
- *The dc control voltage V_c .

Give the expression for the VCO free running frequency.

$$f_o = 0.25 / R_T C_T$$

20. Define Voltage to Frequency conversion factor.

The voltage to frequency conversion factor is an important factor of IC 566. It is denoted as K_v , and defined as,

$$K_v = \frac{\Delta f_c}{\Delta V_c}$$

What is the purpose of having a low pass filter in PLL? *It

removes the high frequency components and noise.

*Controls the dynamic characteristics of the PLL such as capture range, lock-in range, bandwidth and transient response.

*The charge on the filter capacitor gives a short- time memory to the PLL.

22. Write the effect of having large capture range.

The PLL cannot acquire a signal outside the capture range, but once captured, it will hold on till the frequency goes beyond the lock-in range. Thus , to increase the ability of lock range, large capture range is required. But, a large capture range will make the PLL more susceptible to noise and undesirable signal.

Mention some typical applications of PLL:

- Frequency multiplication/division
- Frequency translation
- AM detection
- FM demodulation
- FSK demodulation.

What is a compander IC? Give some examples.

The term companding means compressing and expanding. In a communication system, the audio signal is compressed in the transmitter and expanded in the receiver. Examples: LM 2704- LM 2707; NE 570/571.

25. What are the merits of companding?

- *The compression process reduces the dynamic range of the signal before it is transmitted.
- *Companding preserves the signal to noise ratio of the original signal and avoids non linear distortion of the signal when the input amplitude is large.
- *It also reduces buzz, bias and low level audio tones caused by mild interference.

26. Draw the block diagram and pin configuration of VCO.

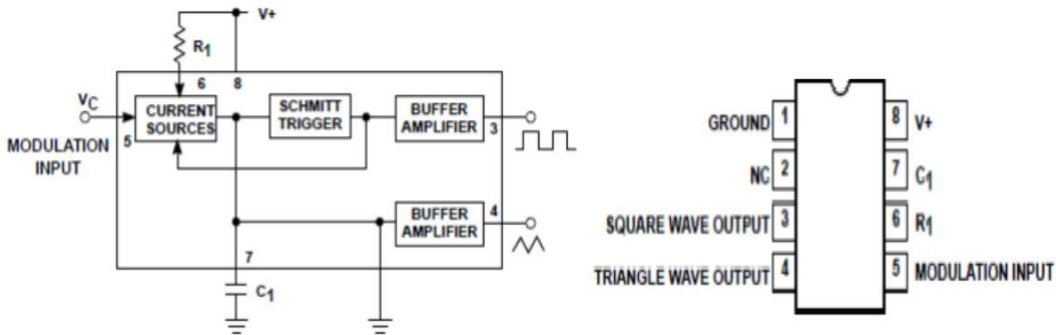

27. Draw the block diagram of IC 565 PLL.

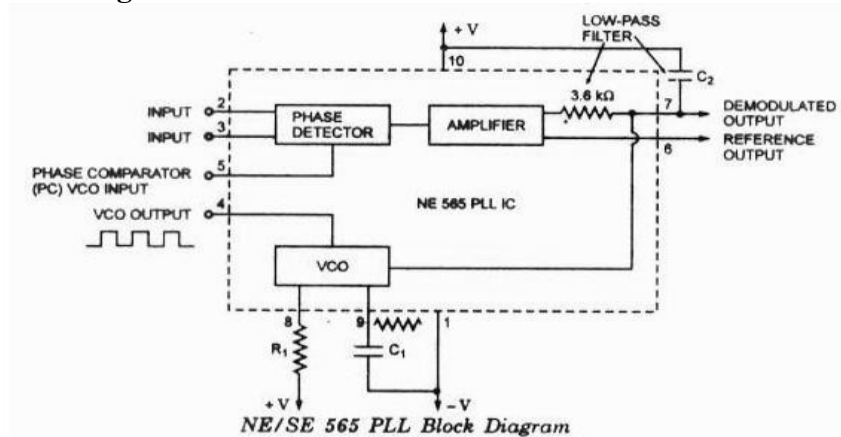

28. Define Frequency synthesizing.

The frequency synthesizer is a circuit that can produce a precise series of frequencies derived from a stable crystal controlled oscillator.

UNIT IV A/D AND D/A CONVERTERS

List the broad classification of ADCs.

- 0 Direct type ADC.
- 1 Integrating type ADC.

List out the direct type ADCs.

- 0 Flash (comparator) type converter
- 1 Counter type converter
- 2 Tracking or servo converter
- 3 Successive approximation type converter

List out some integrating type converters.

- 0 Charge balancing ADC
- 1 Dual slope ADC

What is a sample and hold circuit?

The sample and hold circuit that samples the value of the input signal in response to a sampling command and hold it at the output until arrival of the next command is called sample and hold circuit.

It samples an analog input voltage in a very short period, generally in the range of 1 to 10 microsecond, and holds the sampled voltage level for an extended period, which can range from a few millisecond to several seconds.

5. What is an analog switch?

The switch that connects or disconnects the analog input signal to the output is called analog switch. JFET can be used as an analog switch.

What are the advantages and disadvantages of R-2R ladder DAC.

Advantages:

- a) Easier to build accurately as only two precision metal films are required.
- b) Number of bits can be expanded by adding more sections of same R/2R values.

Disadvantage:

- a) In this type of DAC, when there is a change in the input, changes the current flow in the resistor which causes more power dissipation which creates non-linearity in DAC.

What are the types of ADC and DAC.

Flash (comparator) type converter
 Counter type converter
 Tracking or servo converter
 Successive approximation type converter

Types of DAC:

Weighted resistor DAC
 R-2R Ladder
 Inverted R-2R Ladder

8. What is integrating type converter?

An ADC converter that perform conversion in an indirect manner by first changing the analog I/P signal to a linear function of time or frequency and then to a digital code is known as integrating type A/D converter.

9. Explain in brief the principle of operation of successive Approximation ADC.

The circuit of successive approximation ADC consists of a successive approximation register (SAR), to find the required value of each bit by trial & error. With the arrival of START command, SAR sets the MSB bit to 1. The O/P is converted into an analog signal & it is compared with I/P signal. This O/P is low or High. This process continues until all bits are checked.

What are the main advantages of integrating type ADCs?

⁰ The integrating type of ADC doesn't need a sample/hold circuit at the input.

¹ It is possible to transmit frequency even in noisy environment or in an isolated form.

Where is the successive approximation type ADC's used?

The Successive approximation ADCs are used in applications such as data loggers & instrumentation where conversion speed is important.

12. What is the main drawback of a dual-slop ADC?

The dual slope ADC has long conversion time. This is the main drawback of dual slope ADC.

13. State the advantages of dual slope ADC:

It provides excellent noise rejection of ac signals whose periods are integral multiples of the integration time T.

14. Define conversion time.

It is defined as the total time required to convert an analog signal into its digital output. It depends on the conversion technique used & the propagation delay of circuit components.

The conversion time of a successive approximation type ADC is given by $T(n+1)$ where T---clock period , T_c ---conversion time n----no. of bits

15. Define resolution of a data converter.

The resolution of a converter is the smallest change in voltage which may be produced at the output or input of the converter.

Resolution (in volts)= $V_{FS}/2^n - 1 = 1 \text{ LSB increment}$. The resolution of an ADC is defined as the smallest change in analog input for a one bit change at the output.

Define accuracy of converter.

Absolute accuracy:

It is the maximum deviation between the actual converter output & the ideal converter output.

Relative accuracy:

It is the maximum deviation after gain & offset errors have been removed. The accuracy of a converter is also specified in form of LSB increments or % of full scale voltage.

17. What is settling time?

It represents the time it takes for the output to settle within a specified band $\pm \frac{1}{2} \text{ LSB}$ of its final value following a code change at the input (usually a full scale change). It depends upon the switching time of the logic circuitry due to internal parasitic capacitance & inductances. Settling time ranges from 100ns. 10 μ s depending on word length & type circuit used.

18. Explain in brief stability of a converter:

The performance of converter changes with temperature age & power supply variation . So all the relevant parameters such as offset, gain, linearity error & monotonicity must be specified over the full temperature & power supply ranges to have better stability performances.

19. What is meant by linearity?

The linearity of an ADC/DAC is an important measure of its accuracy & tells us how close the converter output is to its ideal transfer characteristics. The linearity error is usually expressed as a fraction of LSB increment or percentage of full-scale voltage. A good converter exhibits a linearity error of less than $\pm\frac{1}{2}\text{LSB}$.

20. What is monotonic DAC?

A monotonic DAC is one whose analog output increases for an increase in digital input.

21. What is multiplying DAC?

A digital to analog converter which uses a varying reference voltage V_R is called a multiplying DAC(MDAC). If the reference voltage of a DAC, V_R is a sine wave give by

22. What is a sample and hold circuit? Where it is used?

A sample and hold circuit is one which samples an input signal and holds on to its last sampled value until the input is sampled again. This circuit is mainly used in digital interfacing, analog to digital systems, and pulse code modulation systems.

23. Define sample period and hold period.

The time during which the voltage across the capacitor in sample and hold circuit is equal to the input voltage is called sample period. The time period during which the voltage across the capacitor is held constant is called hold period.

24. What is meant by delta modulation?

Delta modulation is a technique capable of performing analog signal quantization with smaller bandwidth requirements. Here, the binary output representing the most recent sampled amplitude will be determined on the basis of previous sampled amplitude levels.

25. Define aperture time.

Because of propagation delays through the driver and switch, V_o will keep tracking V_i some time after the inception of the hold command. This is the aperture time.

26. Define aperture uncertainty.

Aperture uncertainty is the variation in aperture time from sample to sample. Due to aperture uncertainty it is difficult to compensate aperture time by advancing hold command.

27. Define hold mode settling time.

After the applications of hold command, it takes a certain amount of time for V_o to settle within a specified error band, such as 1 %, 0.1 %, or 0.01 %. This is the hold mode settling time.

28. Define voltage droop.

The leakage current causes voltage of the capacitor to drop down. This is referred to as droop.

UNIT V
WAVEFORM GENERATORS & SPECIAL FUNCTION ICs

1. What is a multivibrator?

Multivibrators are a group of regenerative circuits that are used extensively in timing applications. It is a wave shaping circuit which gives symmetric or asymmetric square output. It has two states stable or quasi- stable depending on the type of multivibrator.

2. What do you mean by monostable multivibrator?

Monostable multivibrator is one which generates a single pulse of specified duration in response to each external trigger signal. It has only one stable state. Application of a trigger causes a change to the quasi-stable state. An external trigger signal generated due to charging and discharging of the capacitor produces the transition to the original stable state.

3. What is an astable multivibrator?

Astable multivibrator is a free running oscillator having two quasi-stable states. Thus, there are oscillations between these two states and no external signal is required to produce the change in state.

4. What is a bistable multivibrator?

Bistable multivibrator is one that maintains a given output voltage level unless an external trigger is applied. Application of an external trigger signal causes a change of state, and this output level is maintained indefinitely until a second trigger is applied. Thus, it requires two external triggers before it returns to its initial state

What are the requirements for producing sustained oscillations in feedback circuits?

For sustained oscillations,

- ⁰ The total phase shift around the loop must be zero at the desired frequency of oscillation, f_o .
- ¹ At f_o , the magnitude of the loop gain $|A \beta|$ should be equal to unity.

Mention any two audio frequency oscillators.

- ⁰ RC phase shift oscillator
- ¹ Wein bridge oscillator

Define RC Phase shift oscillator.

RC phase shift oscillator using op amp uses op amp in inverting amplifier mode. It introduces the phase shift of 180° between input and output. The feedback network consists of 3 RC sections each producing 60° phase shift. The output of amplifier is given to the feedback network drives the amplifier. The total phase shift around a loop is 180° of amplifier and 180° due to 3 RC sections, thus 360° . This satisfies the required condition for positive feedback and circuit works as an oscillator.

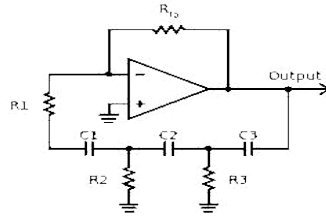

8. Define wien bridge oscillator.

A Wien bridge oscillator is a type of electronic oscillator that generates sine waves. It can generate a large range of frequencies. It uses a non inverting amplifier and hence does not provide any phase shift during amplifier stage. Thus total phase shift is zero and satisfies the oscillatory condition and produces oscillation.

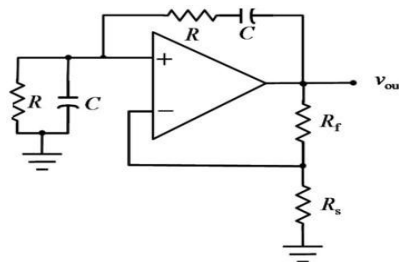

9. Define sawtooth wave generators.

Sawtooth wave has unequal rise time and fall time. The sawtooth wave generator can be implemented by slightly modifying the triangular wave generator.

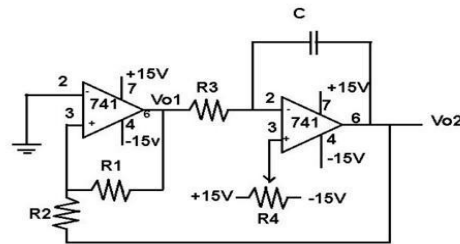

9. Define triangular wave generator.

The triangular wave generator can be formed by simply connecting an integrator to the square wave generator. The triangular wave is generated by alternatively charging and discharging a capacitor with a constant current.

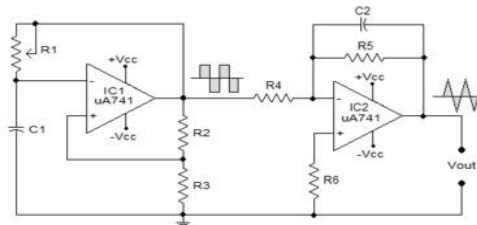

10. Define function generator.

Function generator is used to provide the basic waveforms such as square wave, triangular wave and sine wave. They are also called as waveform generators. It uses VCo to generate triangular

and square waves. The triangular wave is passed through the on chip wave shaper to generate a sine wave.

11. Draw the block diagram and pin configuration of IC 555.

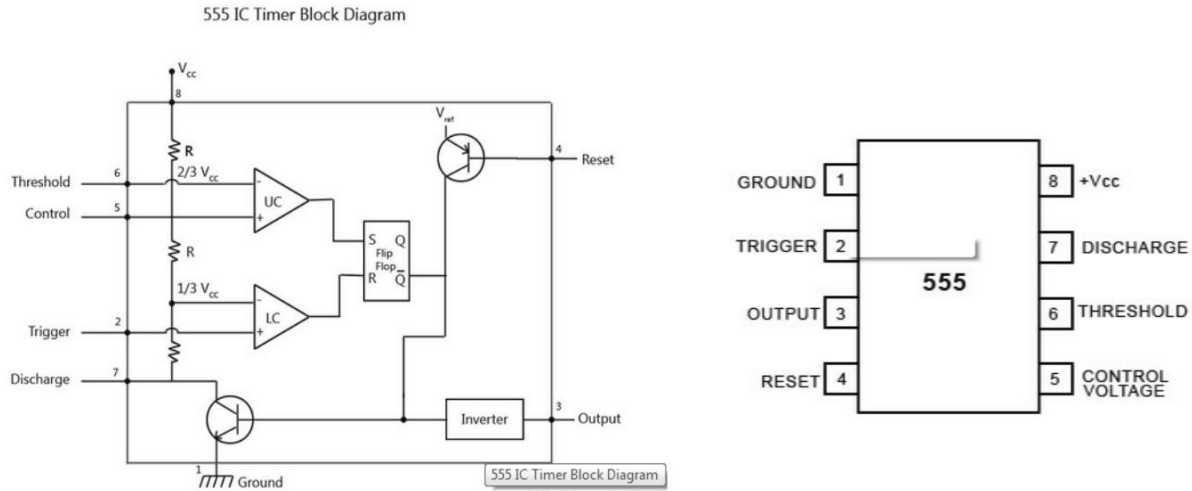

Mention some applications of 555 timers.

- 0 Oscillator
- 1 Pulse generator
- 2 Ramp and square wave generator
- 3 Mono-shot multivibrator
- 4 Burglar alarm
- 5 Traffic light control.

List the applications of 555 timers in monostable mode of operation:

- 0 Missing pulse detector
- 1 Linear ramp generator
- 2 Frequency divider
- 3 Pulse width modulation.

List the applications of 555 timers in Astable mode of operation:

- 0 FSK generator
- 1 Pulse-position modulator

Compare Multivibrators.

S.No.	Monostable multivibrators	Astable multivibrators
1	It has only on stable state	There is no stable state
2	Trigger is required for the operations to change the state.	Trigger is not required to change the state, hence free running.
3	Two components R and C are necessary with IC 555 to obtain	Three components R _A , R _B and C are necessary with IC 555 to

	the circuit.	obtain the circuit.
4	The pulse width is given by $W = 1.1RC$ seconds	The frequency is given by $f = 1.44 / (R_A + 2R_B)$
5	The frequency of operation is controlled by frequency of trigger pulses applied.	The frequency of operation is controlled by R_A , R_B , and C .

15. What is a voltage regulator?

A voltage regulator is an electronic circuit that provides a stable dc voltage independent of the load current, temperature, and ac line voltage variations.

What are the basic elements of voltage regulator?

- The basic elements are
- Voltage reference
- Error amplifier
- Feedback network
- Active series or shunt control element.

Give the classification of voltage regulators:

- 0 Series / Linear regulators
- 1 Switching regulators.

What is Series voltage regulator?

The control element which regulates the load voltage based on the control signal is in series with the load and hence the circuit is called series voltage regulator circuit.

SERIES VOLTAGE REGULATOR - BLOCK DIAGRAM

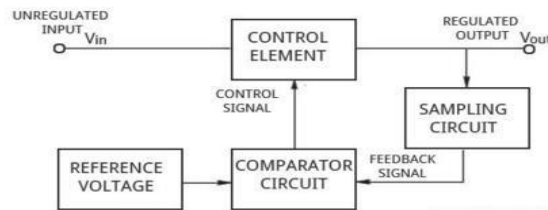

19. What is shunt voltage regulator?

The control element maintains the constant output voltage by shunting the current, hence the circuit is called shunt voltage regulator.

SHUNT VOLTAGE REGULATOR - BLOCK DIAGRAM

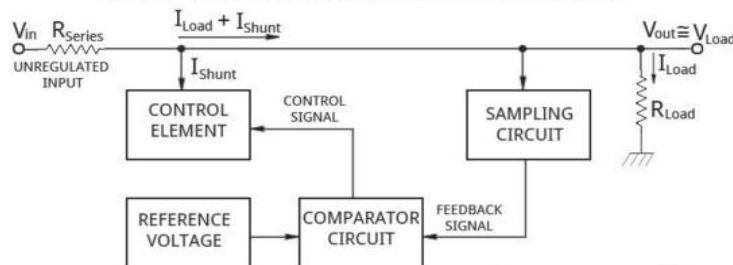

What are the advantages of IC voltage regulator?

- ⁰ Easy to use
- ¹ It greatly simplifies power supply design.
- ² Due to mass production, low in cost.
- ³ IC voltage regulators are versatile.
- ⁴ Conveniently used for local regulation.
- ⁵ These are provided with features like built in protection, programmable output current/voltage boosting, internal short circuit current limiting etc.

What are the important features of IC 723?

- ⁰ It works as voltage regulator at output voltage ranging from 2 to 37 volts at currents upto 150mA.
- ¹ It can be used currents greater than 150 mA with use of suitable NPN or PNP external pass transistors.
- ² Input and output short circuit protection is provided.

What is a linear voltage regulator?

Series or linear regulator uses a power transistor connected in series between the unregulated dc input and the load and it conducts in the linear region .The output voltage is controlled by the continuous voltage drop taking place across the series pass transistor.

What are the limitations of voltage regulator?

The limitations of voltage regulator are:

- ⁰ The required input step down transformer is bulky and expensive.
- ¹ Due to low line frequency, large values of filter capacitors are required.
- ² The efficiency is very low.
- ³ Input must be greater than the output voltage.
- ⁴ As large is the difference between input and output voltage, more is the power dissipation in the series pass transistor.
- ⁵ For higher input voltages, efficiency decreases.
- ⁶ The need for dual supply is not economical and feasible to achieve with the help of linear regulators.

What is a switching regulator?

Switching regulators are those which operate the power transistor as a high frequency on/off switch, so that the power transistor does not conduct current continuously. This gives improved efficiency over series regulators.

What are the advantages of IC voltage regulators?

- ⁰ low cost
- ¹ high reliability
- ² reduction in size
- ³ excellent performance

Give some examples of monolithic IC voltage regulators:

- ⁰ 78XX series fixed output, positive voltage regulators
- ¹ 79XX series fixed output, negative voltage regulators

² 723 general purpose regulators.

What is the purpose of having input and output capacitors in three terminal IC regulators?

A capacitor connected between the input terminal and ground cancels the inductive effects due to long distribution leads. The output capacitor improves the transient response.

Define line regulation.

Line regulation is defined as the percentage change in the output voltage for a change in the input voltage. It is expressed in mill volts or as a percentage of the output voltage.

29. Define load regulation.

Load regulation is defined as the change in output voltage for a change in load current. It is expressed in mill volts or as a percentage of the output voltage.

30. What is meant by current limiting?

Current limiting refers to the ability of a regulator to prevent the load current from increasing above a preset value.

31. Give the drawbacks of linear regulators.

The input step down transformer is bulky and expensive because of low line frequency. Because of low line frequency, large values of filter capacitors are required to decrease the ripple. Efficiency is reduced due to the continuous power dissipation by the transistor as it operates in the linear region.

32. What is the advantage of switching regulators?

*Greater efficiency is achieved as the power transistor is made to operate as low impedance switch. Power transmitted across the transistor is in discrete pulses rather than as a steady current flow.

*By using suitable switching loss reduction technique, the switching frequency can be increased so as to reduce the size and weight of the inductors and capacitors.

Mention the disadvantages of the fixed voltage regulator.

Disadvantages of fixed voltage regulator:

Do not have the short circuit protection

Output voltage is not adjustable.

Draw the inner diagram of IC723 voltage regulator.

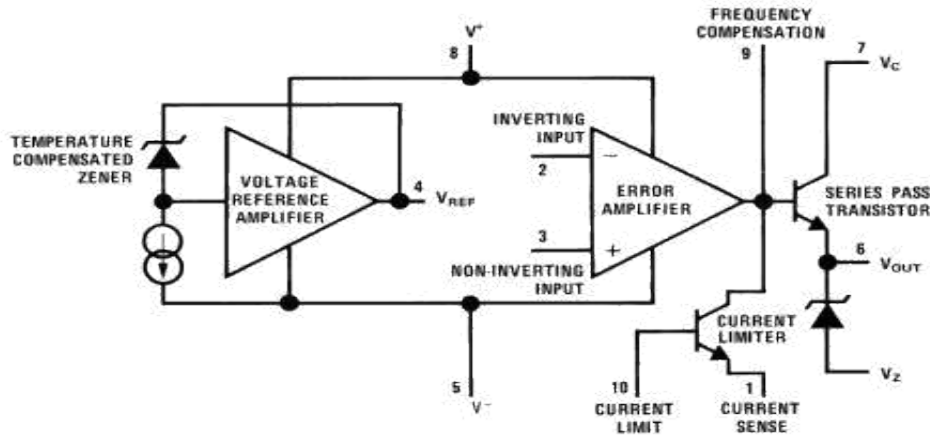

35. What is power amplifier?

The power amplifier is used to amplify an audio signal faithfully. The loads to such amplifiers are generally loud speakers and servomotors. Such loads require large current and sufficient power, typically few watts to tens of watts. Such power amplifiers develop and feed the sufficient power to the loads like speakers, motors etc. by handling the large signals hence these are called as large signal amplifiers or power amplifiers.

Mention the classifications of power amplifiers.

- 0 Class A amplifiers.
- 1 Class B amplifiers
- 2 Class C amplifiers
- 3 Class AB amplifiers.

Mention the features of LM 380 Audio amplifiers.

- Internally fixed gain.
- Wide supply voltage range.
- Output is automatically self centering to one half of the supply voltages.
- Output is short circuit proof with internal thermal limiting.
- Low quiescent power drain. •
- High peak current capability. •
- High input impedance.
- Low total harmonic distortion.
- Standard dual in line package.

Define frequency to voltage converter.

The frequency to voltage converter performs the reverse operations of the VFC. It accepts a wide range and variety of periodic waveforms and produces an analog signal linearly proportional to the input frequency. $V_o = K_f F_{in}$

39. Define video amplifier.

A video amplifier has to amplify signals over a wideband of frequencies, say upto 20Mhz. For proper reproduction of the picture, the shape and form of the video waveform must be preserved during amplification.

40. Draw the internal diagram of LM 380.

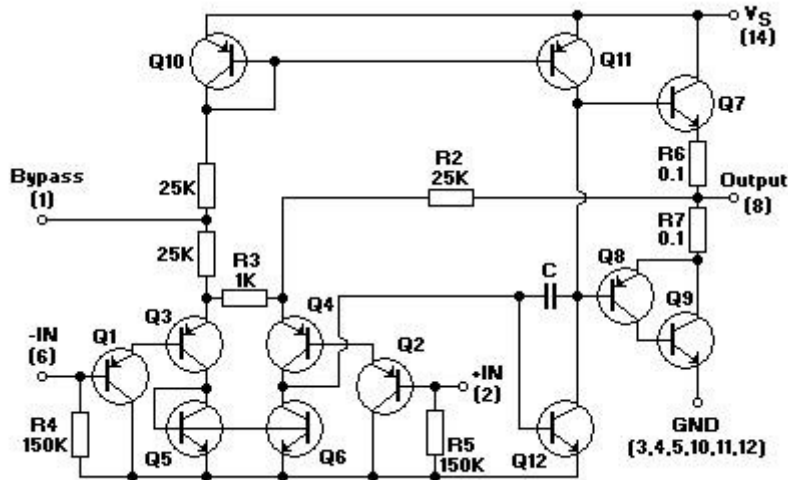

41. What is an opto-coupler IC? Give examples.

Opto-coupler IC is a combined package of a photo-emitting device and a photo sensing device. Examples for opto-coupler circuit: LED and a photo diode, LED and photo transistor, LED and Darlington. Examples for opto-coupler IC: MCT 2F, MCT 2E.

Mention the advantages of opto-couplers:

- 0 Better isolation between the two stages.
- 1 Impedance problem between the stages is eliminated.
- 2 Wide frequency response.
- 3 Easily interfaced with digital circuit.
- 4 Compact and light weight.
- 5 Problems such as noise, transients, contact bounce, are eliminated.

List the characteristics of optocouplers.

- Current transfer ratio.
- Isolation voltage
- Response time
- Common mode rejection
- Bandwidth
- V_{CE} (max)
- I_L (max)

List the types of optocouplers.

- 0 LED – Photodiode
- 1 LED – Photodarlington

45. What is an isolation amplifier?

An isolation amplifier is an amplifier that offers electrical isolation between its input and output terminals.

Name two applications of isolation amplifiers.

- ⁰ Power drives
- ¹ Power test equipments.

What is a switched capacitor filter?

A switched capacitor filter is three terminal device which consists of on chip capacitor and MOS switches with the help of which various elements are simulated. The switches are controlled by the external clock whose frequency can be easily controlled.

Mention the advantages of switched capacitors filters.

- The advantages of switched capacitor filter are,
- ⁰ Very high value of resistors can be easily simulated using small value capacitors, of the order of 10pF.
 - ¹ The switched capacitor filters require no external reactive components like inductors and capacitors.
 - ² Complete active filters can be easily obtained on a monolithic IC chip.
 - ³ The cut off frequencies of switched capacitor filters can be programmed so as to obtain within very high range of frequencies, of the order of 200000 : 1 range.
 - ⁴ Accuracy is very high.
 - ⁵ The overall cost of the system is low.
 - ⁶ Reduction in size.

What is the need for a tuned amplifier?

In radio or TV receivers, it is necessary to select a particular channel among all other available channels. Hence some sort of frequency selective circuit is needed that will allow us to amplify the frequency band required and reject all the other unwanted signals and this function is provided by a tuned amplifier.

Give the classification of tuned amplifier:

- Small signal tuned amplifier
 - Single tuned
 - Double tuned
 - Stagger tuned
- ¹ Large signal tuned amplifier.

Define fiber optics.

A fiber optic technology is well suited for applications like telephony, LAN, WAN where point to point high speed interfaces are required. The rate of data transfer should be high as possible maintaining high degree of accuracy.

PART-B

UNIT-I

- Design an active load for an emitter-coupled pair (differential amplifier) and perform a detailed analysis to find its differential mode gain and the output resistance.
- Design a Widlar current source and obtain the expression for output current. Also prove that widlar current source has better sensitivity than constant current source.
- Explain the supply independent biasing technique using V_{BE} as the reference voltage. Also, find the dependence of its output current on temperature.
- Explain supply independent biasing using zener-referenced bias circuit. Also, design a temperature compensated zener-reference source.
- Obtain the frequency response of an open-loop op-amp and discuss about the methods of frequency compensation.
- What is a current mirror? Discuss in detail about the Wilson current source.
- Write a note on dominant pole compensation used in an op-amp. Explain about Band gap reference.
- Find the slew rate of a frequency compensated op-amp at room temperature which has a unity cross-over frequency of 5MHz.
- Define offset voltage. Explain a method to nullify offset voltage.
- Explain in detail about DC and AC performance characteristics

UNIT-II

- Discuss the need for an instrumentation amplifier? Give a detailed analysis for the same.
- Draw the circuit of a second order Butterworth active low pass filter and derive its transfer function.
- What is a precision diode? With circuit schematic explain the working principle of full wave precision rectifier.
- a) Draw the circuit of an Astable multivibrator using op-amp and derive an expression for its frequency of oscillation.
- ° Discuss in detail the operation of Monostable multivibrator.
- What are the requirements for producing sustained oscillations in feedback circuits? Discuss any two audio frequency oscillators.
- Design a square wave oscillator for $f_o = 1$ KHz using 741 op-amp and a DC supply voltage of +12V to -12V.
- Design an op – amp Schmitt trigger with $V_{UT} = 2V$, $V_{LT} = -4V$ & the output swings between +10V and -10V. If the input is $5 \sin \omega t$, plot input and output waveforms.
- a) If a sine wave of 1V peak at 1000Hz is applied to the differentiator, draw its output waveform.
- ° Draw a BPF using op-amp to have $f_L = 500\text{Hz}$ and $f_H = 2$ KHz with pass band gain of 4.
- Detail the working of log and antilog amplifier.
- a) With neat circuit explain the operation of Schmitt trigger.

0 Explain the working of V to I converter.

UNIT-III

Briefly explain the block diagram of PLL and derive the expression for Lock range and capture range.

With a neat functional diagram, explain the operation of VCO. Also derive an expression for f_0 .

Analyze the Gilbert's four quadrant multiplier cell with a neat circuit diagram.

Explain how a frequency doubler can be realized using this cell.

In detail discuss the applications of PLL.

Explain the purpose and functioning of

Variable trans-conductance multiplier

Frequency synthesizer

Explain the working of PLL. Explain its usage in FM demodulation.

Draw the block diagram of a PLL and derive an expression for its closed loop transfer function.

Explain the working of a VCO. Derive the expression for voltage to frequency conversion factor.

Explain how the IC 565 PLL can be used as a Frequency multiplier/divider

Sketch and explain the multiplier cell using emitter-coupled transistor pair. Prove that the output voltage is proportional to the product of the two input voltages and state their limitations.

UNIT-IV

Explain the working of a voltage to time converter and voltage to frequency converter.

a) Explain the R-2R ladder type DAC.

b) Compare binary weighted DAC with R-2R ladder network DAC.

With circuit schematic explain analog switches using FET.

What are the different sources of error in DAC?

Explain the working principle of DM and ADM.

Explain the working of weighted resistor DAC and discuss the merits and demerits.

Draw the diagram of sample and hold circuit. State how you will reduce its hold mode droop.

Design a 4-bit binary weighted resistor DAC for the following specifications: Use LM741 op-amp, $R = 10\text{k}\Omega$, $V_{\text{ref}} = 2.5\text{V}$ and full scale output = 5V.

A dual slope ADC has a full scale input of 2 Volts. It uses an integrating time of 10ms and integrating capacitor of $0.1\mu\text{f}$. The maximum magnitude of the integrator output should not exceed 3V. Calculate the value of the integrating resistor.

- a) Explain the working of a successive approximation ADC. b)
Explain the working of dual slope ADC

UNIT-V

What is 555 timer? What are the features of 555 timer? Explain the monostable mode in detail?

Explain the Astable mode of operation using 555 timer.

a) In detail discuss the 723 IC general purpose voltage regulator.

b) Explain the operation of switching regulators. Give its advantages.

Explain the functional diagram of LM 380 power amplifier and the essential characteristics.

Explain in detail the function of 555 timer in astable mode and derive the expression for the pulse width.

Write a short notes on

(i) Optocouplers

(ii) Switched capacitor filter

(iii) Isolation amplifier

Explain briefly about audio amplifiers and video amplifiers.

Draw the fundamental block diagram of switching regulator and explain.

Design an adjustable voltage regulator (5V to 15V) with a short circuit current limit of 50 mA using a 723 regulator.

Explain the triangle wave generator with neat diagram and derive the time period.

CONTROL SYSTEM ENGINEERING

EC6405 - CONTROL SYSTEM ENGINEERING

Questions and Answers

Unit - I Control System Modeling

Two marks

1. What is control system?

A system consists of a number of components connected together to perform a specific function. In a system when the output quantity is controlled by varying the input quantity then the system is called control system.

2. What are the two major types of control system?

The two major types of control system are open loop and closed loop system.

3. Define open loop control system.

The control system in which the output quantity has no effect upon the input quantity is called open loop control system. This means that the output is not feedback to the input for correction.

4. Define closed loop control system.

The control system in which the output has an effect upon the input quantity so as to maintain the desired output value is called closed loop control system.

5. What are the components of feedback control system?

The components of feedback control system are plant, feedback path elements, error detector and controller.

6. Define transfer function.

The Transfer Function of a system is defined as the ratio of the Laplace transform of output to Laplace transform of input with zero initial conditions.

What are the basic elements used for modeling mechanical translational system? 1.

Mass

⁰ Spring

¹ Dashpot.

What are the basic elements used for modeling mechanical rotational system?

⁰ Moment of inertia J,

¹ Dashpot with rotational frictional coefficient B and

² Torsion spring with stiffness K

Name two types of electrical analogous for mechanical system.

The two types of analogies for the mechanical system are force voltage and force current analogy.

10. What is Block Diagram?

A Block Diagram of a system is a pictorial representation of the functions performed by each component of the system and shows the flow of signals. The basic elements of block diagram are blocks, branch point and summing point.

11. What is the basis for framing the rules of block diagram reduction technique?

The rules for block diagram reduction technique are framed such that any modification made on the diagram does not alter the input output relation.

12. What is a signal flow graph?

A signal flow graph is a diagram that represents a set of simultaneous algebraic equations. By taking Laplace transform the time domain differential equations governing a control system can be transferred to a set of algebraic equations in s-domain.

13. What is transmittance?

The transmittance is the gain acquired by the signal when it travels from one node to another node in signal flow graph.

14. What is sink and source?

Source is the input node in the signal flow graph and it has only outgoing branches. Sink is a output node in the signal flow graph and it has only incoming branches.

15. Define non touching loop.

The loops are said to be non touching if they do not have common nodes.

16. Write Masons Gain formula.

Masons Gain formula states that the overall gain of the system is $T = (1/\Delta) \times$

$(\Delta_k P_k)$ k-No.of forward paths in the signal flow graph.

P_k - Forward path gain of k^{th} forward path

$\Delta_k = 1 - [\text{sum of individual loop gains}] + [\text{sum of gain products of all possible combinations of two non touching loops}] - [\text{sum of gain products of all possible combinations of three non touching loops}] + \dots$

k - for that part of the graph which is not touching k^{th} forward path.

Write the analogous electrical elements in force voltage analogy for the elements of mechanical translational system.

Force-voltage-e, Velocity-v, current-I, Displacement-x, charge-q

Frictional coeff-B, Resistance-R, Mass-M, Inductance-L, Stiffness-K,

Inverse of capacitance-1/C

Write the analogous electrical elements in force current analogy for the Elements of mechanical translational system.

Force-current-i, Velocity-v, voltage-v, Displacement-x, flux-

Frictional coefficient-B, conductance-1/R, Mass-M, capacitance- C, Stiffness-K,

Inverse of inductance-1/L

Write the force balance equation of an ideal mass element. $F =$

$$M \frac{d^2 x}{dt^2}$$

Write the force balance equation of ideal dashpot.

$$F = B \frac{dx}{dt}$$

Write the force balance equation of ideal spring element. $F =$

$$= Kx$$

What is servomechanism?

The servomechanism is a feedback control system in which the output is mechanical position (or time derivatives of position velocity and acceleration)

23. Why is negative feedback invariably preferred in closed loop system?

The negative feedback results in better stability in steady state and rejects any disturbance signals.

Unit - II Time Response Analysis

Two marks

1. What is transient response?

The transient response is the response of the system when the system changes from one state to another.

2. What is steady state response?

The steady state response is the response of the system when it approaches infinity.

3. What is an order of a system?

The order of a system is the order of the differential equation governing the system. The order of the system can be obtained from the transfer function of the given system.

4. Define Damping ratio.

Damping ratio is defined as the ratio of actual damping to critical damping.

List the time domain specifications.

The time domain specifications are

- ⁰ Delay time
- ¹ Rise time
- ² Peak time
- ³ Peak overshoot

Define Delay time.

The time taken for response to reach 50% of final value for the very first time is delay time.

7. Define Rise time.

The time taken for response to raise from 0% to 100% for the very first time is rise time.

8. Define peak time.

The time taken for the response to reach the peak value for the first time is peak time.

9. Define peak overshoot.

Peak overshoot is defined as the ratio of maximum peak value measured from the maximum value to final value.

10. Define Settling time.

Settling time is defined as the time taken by the response to reach and stay within specified error.

11. What is the need for a controller?

The controller is provided to modify the error signal for better control action.

What are the different types of controllers?

0 Proportional controller

1 PI controller

2 PD controller

3 PID controller

What is Proportional controller?

It is a device that produces a control signal which is proportional to the input error signal.

14. What is PI controller?

It is a device that produces a control signal consisting of two terms - one proportional to error signal and the other proportional to the integral of error signal.

15. What is PD controller?

PD controller is a proportional plus derivative controller which produces an output signal consisting of two time - one proportional to error signal and other proportional to the derivative of the signal.

What is the significance of integral controller and proportional controller in a PID controller?

0 The Proportional controller stabilizes the gain but produces a steady state error.

1 The Integral control reduces or eliminates the steady state error.

Why derivative controller is not used in control systems?

The derivative controller produces a control action based on the rate of change of error signal and it does not produce corrective measures for any constant error.

18. Define Steady state error.

The steady state error is defined as the value of error as time tends to infinity.

19. What is the drawback of static coefficients?

The main drawback of static coefficient is that it does not show the variation of error

with time and input should be standard input.

20. What is step signal?

The step signal is a signal whose value changes from zero to A at $t=0$ and remains constant at A for $t>0$.

21. What is ramp signal?

The ramp signal is a signal whose value increases linearly with time from an initial value of zero at $t=0$. The ramp signal resembles a constant velocity.

22. What is a parabolic signal?

The parabolic signal is a signal whose value varies as a square of time from an initial value of zero at $t=0$. This parabolic signal represents constant acceleration input to the signal.

What are the three constants associated with a steady state error?

- ⁰ Positional error constant
- ¹ Velocity error constant
- iii. Acceleration error constant

What are the main advantages of generalized error coefficients?

- ⁰ Steady state is function of time.
- ¹ Steady state can be determined from any type of input.

What are the effects of adding a zero to a system?

Adding a zero to a system results in pronounced early peak to system response thereby the peak overshoot increases appreciably.

26. What is steady state error?

The steady state error is the value of error signal $e(t)$ when t tends to infinity.

27. Name the test signals used in control system.

The commonly used test input signals in control system are impulse step ramp acceleration and sinusoidal signals.

28. What are static error constants?

The K_p , K_v and K_a are called static error constants.

29. What is the disadvantage in proportional controller?

The disadvantage in proportional controller is that it produces a constant steady state error.

30. What is the effect of PD controller on system performance?

The effect of PD controller is to increase the damping ratio of the system and so the peak overshoot is reduced.

31. What is the effect of PI controller on the system performance?

The PI controller increases the order of the system by one, which results in reducing the steady state error. But the system becomes less stable than the original system.

Unit - III Frequency Response Analysis

Two marks

1. What is frequency response?

A frequency response is the steady state response of a system when the input to the system is a sinusoidal signal.

List out the different frequency domain specifications.

The frequency domain specifications are

⁰ Resonant peak.

¹ Resonant frequency.

Define Resonant Peak (Δr)

The maximum value of the magnitude of closed loop transfer function is called Resonant Peak.

4. Define Resonant frequency (Δf)

The frequency at which resonant peak occurs is called resonant frequency.

5. What is Bandwidth?

The Bandwidth is the range of frequencies for which the system gain is more than 3 dB. The bandwidth is a measure of the ability of a feedback system to reproduce the input signal noise rejection characteristics and rise time.

6. Define Cut off rate.

The slope of the log-magnitude curve near the cut-off is called cut-off rate. The cut off rate indicates the ability to distinguish the signal from noise.

7. Define Gain Margin.

The Gain Margin, k_g is defined as the reciprocal of the magnitude of the open loop transfer function at phase cross over frequency.

Define Gain margin formula.

Gain margin $k_g = 1 / \Delta G(j\Delta_{pc})\Delta$.

Define Phase cross over.

The frequency at which, the phase of open loop transfer functions is called phase cross over frequency Δ_{pc} .

10. What is Phase margin?

The Phase margin is the amount of phase lag at the gain cross over frequency required to bring system to the verge of instability.

11. Define Gain cross over.

The Gain cross over frequency Δ_{gc} is the frequency at which the magnitude of the open loop transfer function is unity.

12. What is Bode plot?

The Bode plot is the frequency response plot of the transfer function of a system. A Bode plot consists of two graphs. One is the plot of magnitude of sinusoidal transfer function versus $\log \Delta$. The other is a plot of the phase angle of a sinusoidal function versus $\log \Delta$.

What are the main advantages of Bode plot?

The main advantages are:

- ⁰ Multiplication of magnitude can be into addition.
- ¹ A simple method for sketching an approximate log curve is available.
- ² It is based on asymptotic approximation. Such approximation is sufficient if rough information on the frequency response characteristic is needed.
- ³ The phase angle curves can be easily drawn if a template for the phase angle curve of $1 + j\Delta$ is available.

Define Corner frequency.

The frequency at which the two asymptotic meet in a magnitude plot is called Corner frequency.

15. Define Phase lag and phase lead.

A negative phase angle is called phase lag. A positive phase angle is called phase lead.

16. What are M circles?

The magnitude of closed loop transfer function with unit feedback can be shown for every value of M. These circles are called M circles.

17. What is Nichols chart?

The chart consisting of M & N loci in the log magnitude versus phase diagram is called Nichols chart.

18. What are two contours of Nichols chart?

Nichols chart of M and N contours, superimposed on ordinary graph. The M contours are the magnitude of closed loop system in decibels and the N contours are the phase angle locus of closed loop system.

19. How is the Resonant Peak (M_R), resonant frequency (ω_R), and band width determined from Nichols chart?

The resonant peak is given by the value of M -contour which is tangent to $G(j\omega)$ locus.

The resonant frequency is given by the frequency of $G(j\omega)$ at the tangency point.

The bandwidth is given by frequency corresponding to the intersection point of $G(j\omega)$ and $-3\text{dB } M$ -contour.

What are the advantages of Nichols chart?

The advantages are:

- i) It is used to find the closed loop frequency response from open loop frequency response.
- ii) Frequency domain specifications can be determined from Nichols chart.
- iii) The gain of the system can be adjusted to satisfy the given specification.

What are the two types of compensation?

- ⁰ Cascade or series compensation
- ¹ Feedback compensation or parallel compensation.

What are the three types of compensators?

- ⁰ Lag compensator
- ¹ Lead compensator

¹ Lag-Lead compensator.

What are the uses of lead compensator?

- ⁰ Speeds up the transient response
- ¹ Increases the margin of stability of a system
- ² Increases the system error constant to a limited extent.

What is the use of lag compensator?

Improve the steady state behavior of a system, while nearly preserving its transient response.

25. When lag lead compensator is required?

The lag lead compensator is required when both the transient and steady state response of a system has to be improved.

26. What is a compensator?

A device inserted into the system for the purpose of satisfying the specifications is called as a compensator.

Unit - IV Stability Analysis

Two marks

1. What is Nyquist contour?

The contour that encloses entire right half of S plane is called Nyquist contour.

2. State Nyquist stability criterion.

If the Nyquist plot of the open loop transfer function $G(s)$ corresponding to the Nyquist control in the S-plane encircles the critical point $-1+j0$ in the counter clockwise direction as many times as the number of right half S-plane poles of $G(s)$, the closed loop system is stable.

3. Define Relative stability.

Relative stability is the degree of closeness of the system, it is an indication of strength or degree of stability.

What are the two segments of Nyquist contour?

- ⁰ A finite line segment C_1 along the imaginary axis.
- ¹ An arc C_2 of infinite radius.

5. What are root loci?

The path taken by the roots of the open loop transfer function when the loop gain is varied from 0 to ∞ are called root loci.

6. What is a dominant pole?

The dominant pole is a complex conjugate pair which decides the transient response of the system.

7. What are the main significances of root locus?

The main root locus technique is used for stability analysis.

Using root locus technique the range of values of K , for a stable system can be determined.

8. What are the effects of adding a zero to a system?

Adding a zero to a system increases peak overshoot appreciably.

9. Define stability.

A linear relaxed system is said to have BIBO stability if every bounded input results in a bounded output.

What will be the nature of impulse response when the roots of characteristic equation are lying on imaginary axis?

If the root of characteristic equation lies on imaginary axis the nature of impulse response is oscillatory.

What is the relationship between Stability and coefficient of characteristic polynomial?

If the coefficient of characteristic polynomial are negative or zero, then some of the roots lie on the negative half of the S-plane. Hence the system is unstable. If the coefficients of the characteristic polynomial are positive and if no coefficient is zero then there is a possibility of the system to be stable provided all the roots are lying on the left half of the S-plane.

12. What is Routh stability criterion?

Routh criterion states that the necessary and sufficient condition for stability is that all of the elements in the first column of the Routh array is positive. If this condition is not met, the

system is unstable and the number of sign changes in the elements of the first column of routh array corresponds to the number of roots of characteristic equation in the right half of the S-plane.

13. What is limitedly stable system?

For a bounded input signal if the output has constant amplitude oscillations, then the system may be stable or unstable under some limited constraints such a system is called limitedly stable system.

14. In Routh array what conclusion you can make when there is a row of all zeros?

All zero rows in the routh array indicate the existence of an even polynomial as a factor of the given characteristic equation. The even polynomial may have roots on imaginary axis.

15. What is a principle of argument?

The principles of arguments states that let $F(S)$ are analytic function and if an arbitrary closed contour in a clockwise direction is chosen in the S-plane so that $F(S)$ is analytic at every point of the contour. Then the corresponding $F(S)$ plane contour mapped in the $F(S)$ plane will encircle the origin N times in the anti clockwise direction, where N is the difference between number of poles and zeros of $F(S)$ that are encircled by the chosen closed contour in the S-plane.

16. What are the main significances of root locus?

The root locus technique is used for stability analysis.

Using root locus technique the range of values of K , for as stable system can be determined.

17. What are break away and break in points?

At break away point the root locus breaks from the real axis to enter into the complex plane. At break in point the root locus enters the real axis from the complex plane. To find the break away or break in points, form a equation for K from the characteristic equation and differentiate the equation of K with respect to s . Then find the roots of the equation $dK/dS = 0$. The roots of $dK/dS = 0$ are break away or break in points provided for this value of root the gain K should be positive and real.

What are asymptotes? How will you find angle of asymptotes?

Asymptotes are the straight lines which are parallel to root locus going to infinity and meet the root locus at infinity.

Angles of asymptotes = $\pm 180^\circ(2q + 1)/(p-z)$ $q= 0,1,2, \dots\dots(p-z-1)$

p-number of poles.

z-number of zeros.

19. What is centroid?

The meeting point of the asymptotes with the real axis is called centroid. The centroid is given by

Centroid = (sum of poles – sum of zeros) / (p-z)

p-number of poles. z-

number of zeros.

20. What is magnitude criterion?

The magnitude criterion states that $s=s_a$ will be a point on root locus if for that value of S, magnitude of $G(S)H(S)$ is equal to 1.

$|G(S)H(S)| = K$ (product of length of vectors from open loop zeros to the point $s=s_a$) / (product of length of vectors from open loop poles to the point $s=s_a$) = 1.

21. What is angle criterion?

The angle criterion states that $s=s_a$ will be the point on the root locus if for that value of S the argument or phase of $G(S)H(S)$ is equal to an odd multiple of 180° .

(Sum of the angles of vectors from zeros to the point $s=s_a$) - (Sum of the angles of vectors from poles to the point $s=s_a$) = $\pm 180^\circ(2q + 1)$

22. How will you find the root locus on real axis?

To find the root loci on real axis, choose the test point on real axis. If the total number of poles and zeros on the real axis to the right of this test point is odd number then the test point lie on the root locus. If it is even then the test point does not lie on the root locus.

23. What is characteristic equation?

The denominator polynomial of $C(S)/R(S)$ is the characteristic equation of the system. **24. How the roots of characteristic are related to stability?**

If the root of characteristic equation has positive real part then the impulse response of the system is not bounded. Hence the system will be unstable. If the root has negative real parts

then the impulse response is bounded. Hence the system will be stable.

25. What is the necessary condition for stability?

The necessary condition for stability is that all the coefficients of the characteristic polynomial be positive. The necessary and sufficient condition for stability is that all of the elements in the first column of the routh array should be positive.

26. What are the requirements for BIBO Stability?

The requirement of the BIBO stability is that the absolute integral of the impulse response of the system should take only the finite value.

27. What is auxiliary polynomial?

In the construction of routh array a row of all zero indicates the existence of an even polynomial as a factor of given characteristic equation. In an even polynomial the exponents of S are even integers or zero only. This even polynomial factor is called auxiliary polynomial. The coefficients of auxiliary polynomial are given by the elements of the row just above the row of all zeros.

Unit - V State Variable Analysis

Two marks

1. State sampling theorem.

A continuous time signal can be completely represented in its samples and recovered back if the sampling frequency $F_s \geq 2F_{max}$ where F_s is the sampling frequency and F_{max} is the maximum frequency present in the signal.

2. What is periodic sampling?

Sampling of a signal at uniform equal intervals is called periodic sampling.

3. What are hold circuits & explain it.

The function of the hold circuit is to reconstruct the signal which is applied as input to the sampler. The simplest holding device holds the signal between two consecutive instants at its preceded value till next sampling instant is reached.

What are the problems encountered in a practical hold circuits?

Hold mode may drop occur, nonlinear variation during sampling aperture, error in the periodicity of sampling.

5. What are the advantages of state space analysis?

It can be applied to non-linear as well as time varying systems. Any type of input can be considered for designing the system. It can be conveniently applied to multiple input multiple output systems. The state variables selected need not necessarily be the physical quantities of the system.

6. What are phase variables?

The phase variables are defined as the state variables which are obtained from one of the system variables and its derivatives.

7. Define state variable.

The state of a dynamical system is a minimal set of variables (known as state variables) such that the knowledge of these variables at $t=t_0$ together with the knowledge of the inputs for $t > t_0$, completely determines the behavior of the system for $t > t_0$.

8. Write the general form of state variable matrix.

The most general state-space representation of a linear system with m inputs, p outputs and n state variables is written in the following form:

$$\begin{aligned} \dot{X} &= AX + BU \\ Y &= CX + DU \end{aligned}$$

Where X = state vector of order $n \times 1$. U

input vector of order $n \times 1$.

A = System matrix of order $n \times n$.

B = Input matrix of order $n \times m$ C

= output matrix of order $p \times n$

D = transmission matrix of order $p \times m$.

9. Write the relationship between z-domain and s-domain.

All the poles lying in the left half of the S -plane, the system is stable in S -domain. Corresponding in Z -domain all poles lie within the unit circle.

What are the methods available for the stability analysis of sampled data control system?

The following three methods are available for the stability analysis of sampled data

control system

- ⁰ Jury's stability test.
- ¹ Bilinear transformation.
- ² Root locus technique.

What is the necessary condition to be satisfied for design using state feedback?

The state feedback design requires arbitrary pole placements to achieve the desired performance. The necessary and sufficient condition to be satisfied for arbitrary pole placement is that the system is completely state controllable.

12. What is controllability?

A system is said to be completely state controllable if it is possible to transfer the system state from any initial state $X(t_0)$ at any other desired state $X(t)$, in specified finite time by a control vector $U(t)$.

13. What is observability?

A system is said to be completely observable if every state $X(t)$ can be completely identified by measurements of the output $Y(t)$ over a finite time interval.

Write the properties of state transition matrix. The following are the properties of state transition matrix

$$^0 \quad \Phi(0) = e^{Ax0} = I \text{ (unit matrix).}$$

$$^1 \quad \Phi(t) = e^{At} = (e^{-At})^{-1} = [\Phi(-t)]^{-1}.$$

$$^2 \quad \Phi(t_1+t_2) = e^{A(t_1+t_2)} = \Phi(t_1) \Phi(t_2) = \Phi(t_2) \Phi(t_1).$$

What is sampled data control system?

When the signal or information at any or some points in a system is in the form of discrete pulses, then the system is called discrete data system or sampled data system.

16. What is Nyquist rate?

The Sampling frequency equal to twice the highest frequency of the signal is called as Nyquist rate. $f_s=2f_m$.

17. What is meant by diagonalization?

The process of converting the system matrix A into a diagonal matrix by a similarity transformation using the modal matrix M is called diagonalization.

18. What is modal matrix?

The modal matrix is a matrix used to diagonalize the system matrix. It is also called diagonalization matrix.

If A = system matrix.

M = Modal matrix

And M^{-1} = inverse of modal matrix.

Then $M^{-1}AM$ will be a diagonalized system matrix.

19. How the modal matrix is determined?

The modal matrix M can be formed from eigenvectors. Let $m_1, m_2, m_3 \dots m_n$ be the eigen vectors of the n^{th} order system. Now the modal matrix M is obtained by arranging all the eigenvectors column wise as shown below.

Modal matrix , $M = [m_1, m_2, m_3 \dots m_n]$.

20. What is the need for controllability test?

The controllability test is necessary to find the usefulness of a state variable. If the state variables are controllable then by controlling (i.e. varying) the state variables the desired outputs of the system are achieved.

21. What is the need for observability test?

The observability test is necessary to find whether the state variables are measurable or not. If the state variables are measurable then the state of the system can be determined by practical measurements of the state variables.

22. State the condition for controllability by Gilbert's method.

Case (i) when the eigen values are distinct

Consider the canonical form of state model shown below which is obtained by using the transformation $X=MZ$.

$$\dot{Z} = \Lambda Z + U$$

$$Y = Z + DU$$

Where, $\Lambda = M^{-1}AM$; $C = CM$, $D = M^{-1}B$ and M = Modal matrix.

In this case the necessary and sufficient condition for complete controllability is that, the matrix must have no row with all zeros. If any row of the matrix is zero then the corresponding state variable is uncontrollable.

Case (ii) when eigen values have multiplicity

In this case the state modal can be converted to Jordan canonical form shown below =
 $JZ + U$

$$Y=Z + DU \text{ Where, } J = M^{-1}AM$$

In this case the system is completely controllable, if the elements of any row of that correspond to the last row of each Jordan block are not all zero.

23. State the condition for observability by Gilbert's method.

Consider the transformed canonical or Jordan canonical form of the state model shown below which is obtained by using the transformation, $X =MZ$

$$= \Lambda Z + U$$

$$Y=Z + DU \text{ (Or)}$$

$$= JZ + U$$

$$Y=Z + DU \text{ where } =CM \text{ and } M=\text{modal matrix.}$$

The necessary and sufficient condition for complete observability is that none of the columns of the matrix be zero. If any of the column is of has all zeros then the corresponding state variable is not observable.

24. State the duality between controllability and observability.

The concept of controllability and observability are dual concepts and it is proposed by kalman as principle of duality. The principle of duality states that a system is completely state controllable if and only if its dual system is completely state controllable if and only if its dual system is completely observable or vice versa.

25. What is the need for state observer?

In certain systems the state variables may not be available for measurement and feedback. In such situations we need to estimate the un measurable state variables from the knowledge of input and output. Hence a state observer is employed which estimates the state variables from the input and output of the system. The estimated state variable can be used for feedback to design the system by pole placement.

How will you find the transformation matrix, P_0 to transform the state model to observable phase variable form?

⁰ Compute the composite matrix for observability, Q_0

Determine the characteristic equation of the system $|\lambda I - A| = 0$.

Using the coefficients a_1, a_2, \dots, a_{n-1} of characteristic equation form a matrix, W .

Now the transformation matrix, P_0 is given by $P_0 = W Q_0^T$.

27. Write the observable phase variable form of state model.

The observable phase variable form of state model is given by the following equations =

$$\begin{aligned} A_0 Z + B_0 u \\ \dot{z} = C_0 Z + D u \end{aligned}$$

Where, $A_0 =$, $B_0 =$ and $C_0 = [0 \ 0 \ \dots \ 0 \ 1]$

What is the pole placement by state feedback?

The pole placement by state feedback is a control system design technique, in which the state variables are used for feedback to achieve the desired closed loop poles.

29. How control system design is carried in state space?

In state space design of control system, any inner parameter or variable of a system are used for feedback to achieve the desired performance of the system. The performance of the system is related to the location of closed loop poles. Hence in state space design the closed loop poles are placed at the desired location by means of state feedback through an appropriate state feedback gain matrix, K .

PART B

UNIT - I

1. Draw the signal flow graph and find C/R for the figure shown.

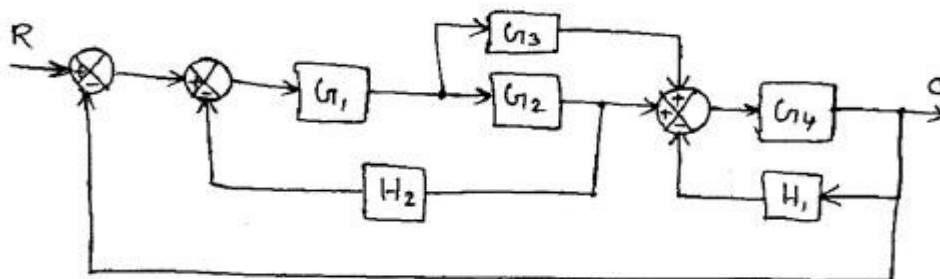

Write the differential equations and obtain $X_3(S)/F(S)$ for the mechanical system shown. Also draw the force voltage and force current analogies.

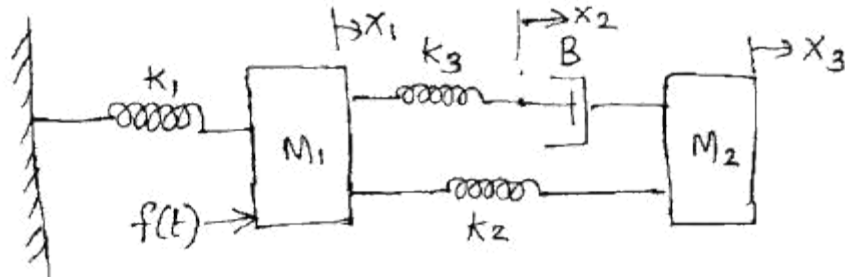

- a) (i) Reduce the block diagram given below to find the closed loop Transfer function by reduction method when the I/P R is at station-II
 (ii) Reduce the block diagram given above to find the closed loop Transfer function by signal flow graph when the I/P R is at station-I

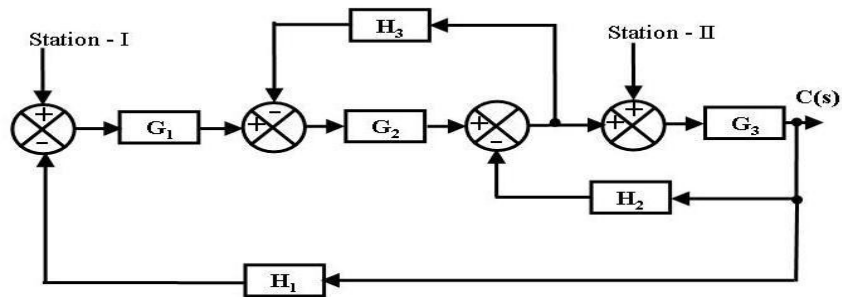

4. Obtain Transfer function of the system.

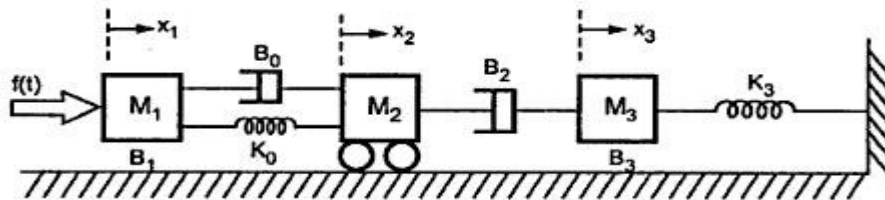

5. Obtain analogous electrical network.

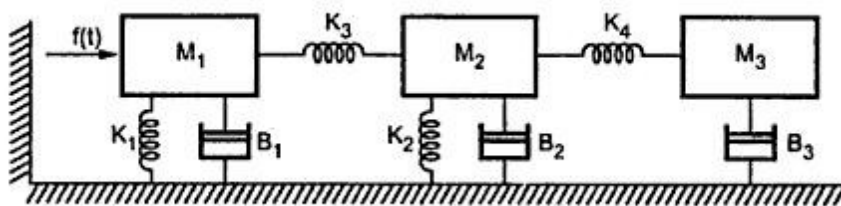

Using mason's gain formula find C/R.

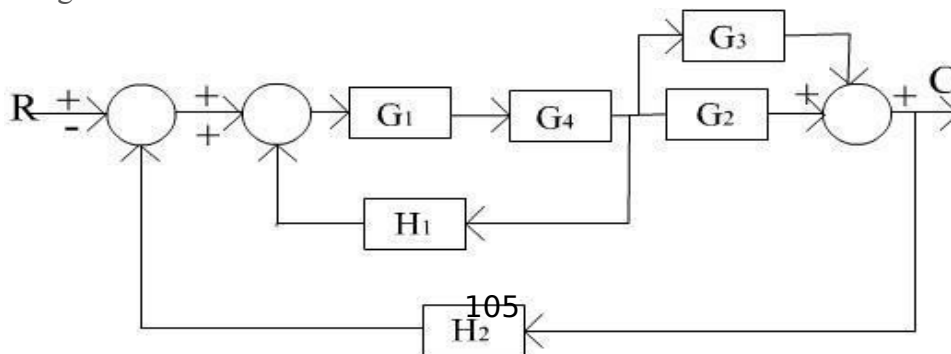

Write the differential equations governing the mechanical system. Draw the force-voltage and force current electrical analogous circuits and verify by writing mesh and node equations.

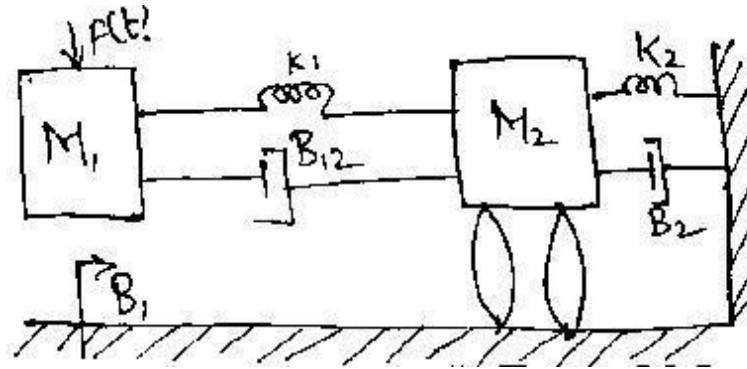

8. Using Mason's gain formula, find C/R of the signal flow graph shown in figure.

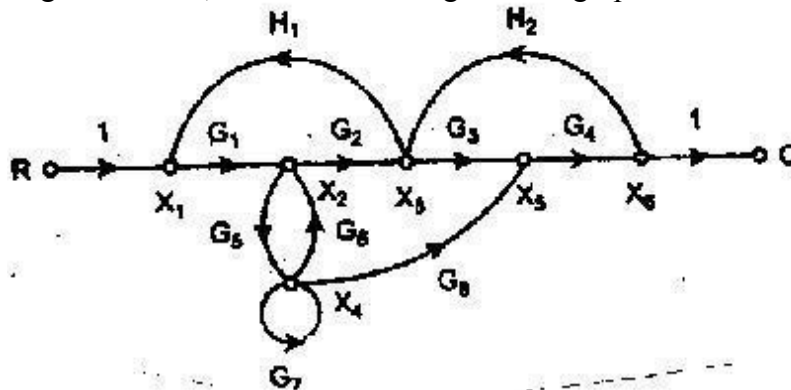

Derive the transfer function for Armature controlled DC servo motor.

Derive the transfer function for Field controlled DC servo motor.

UNIT - II

(a) Derive the expressions and draw the response of first order system for unit step input.

⁰ Draw the response of second order system for critically damped case and when input is unit step.

Derive the expressions for Rise time, Peak time, Peak overshoot.

Derive the response of undamped second order system for unit step input.

k

4. The unity feedback system is characterized by an open loop transfer function is $\frac{k}{s(s+10)}$.

Determine the gain k so that system will have damping ratio of 0.5. For this value of k , determine peak overshoot and peak time for a unit step input.

A positional control system with velocity feedback is shown in fig. What is the response $c(t)$ to the unit step input. Given that $\zeta = 0.5$ and also calculate rise time, peak time, Maximum overshoot and settling time.

A unity feedback control system has an open loop transfer function $G(S) = 10/S(S+2)$. Find the rise time, percentage overshoot, peak time and settling time.

Consider a second order model $Y(s)/R(s) = \omega_n^2 / (S^2 + 2\xi\omega_n S + \omega_n^2)$; $0 < \xi < 1$. Find the response $y(t)$ to a unit step function.

8. For a unity feedback control system the open loop transfer function $G(S) = 10(S+2)/S^2(S+1)$. Find (a) position, velocity and acceleration error constants. (b) The steady state error when the input is $R(S) = 3/S - 2/S^2 + 1/3S^3$

The open loop transfer function of a servo system with unity feedback system is $G(S) = 10/S(0.1S+1)$. Evaluate the static error constants of the system. Obtain the steady state error of the system when subjected to an input given by the polynomial $r(t) = a_0 + a_1t + a_2/2 t^2$.

The open loop transfer function of a system with unity feedback gain is given as $G(S) = 20/S^2 + 5S + 6$. Determine the damping ratio, maximum overshoot, rise time and peak time. Derive the used formulae.

Evaluate the static error constants for a unity feedback system having a forward path transfer function $G(S) = 50/S(S+10)$. Estimate the steady state errors of the system for the input $r(t)$ given by $r(t) = 1 + 2t + t^2$.

The closed loop transfer function of a second order system is given by

$$T(s) = \frac{100}{s^2 + 10s + 100}$$

Determine the damping ratio, natural frequency of oscillations, rise time, settling time and peak overshoot.

13. With necessary diagrams explain the P,PI,PD controller and explain its output equations.

UNIT - III

Sketch the Bode plot for the system $G(s) = K(e^{-0.2s})/s(s+2)(s+8)$. Find the value of K so that the system is stable with gain margin = 6 db and phase margin = 45 degree.

The open loop transfer function of a unity feedback system is $G(S) = 1/S(1+S)(1+2S)$. Sketch the Polar plot and determine the Gain margin and Phase margin.

Sketch the Bode plot and hence find Gain cross over frequency, Phase cross over frequency, Gain margin and Phase margin. $G(S) = 0.75(1+0.2S)/S(1+0.5S)(1+0.1S)$

Sketch the Bode plot and hence find Gain cross over frequency, Phase cross over frequency, Gain margin and Phase margin. $G(S) = 10(S+3)/S(S+2)(S^2+4S+100)$

Sketch the polar plot for the following transfer function and find Gain cross over frequency, Phase cross over frequency, Gain margin and Phase margin. $G(S) = 10(S+2)(S+4) / S(S^2 - 3S+10)$

Construct the polar plot for the function $GH(S) = 2(S+1) / S^2$. Find Gain cross over frequency, Phase cross over frequency, Gain margin and Phase margin.

Plot the Bode diagram for the following transfer function and obtain the gain and phase cross over frequencies. $G(S) = KS^2 / (1+0.2S)(1+0.02S)$. Determine the value of K for a gain cross over frequency of 20 rad/sec.

Sketch the polar plot for the following transfer function and find Gain cross over frequency, Phase cross over frequency, Gain margin and Phase margin. $G(S) = 400 / S(S+2)(S+10)$.

Derive the expression for Lag - Lead compensator and also find its frequency response.

Sketch the Bode plot and hence find Gain cross over frequency, Phase cross over frequency, Gain margin and Phase margin. $G(S) = 10(1+0.1S) / S(1+0.01S)(1+S)$.

Explain the closed loop frequency response with the help of M and N circles.

Explain in detail the design procedure of lead compensator using Bode plot.

UNIT - IV

Obtain Routh array for the system whose characteristic polynomial equation is given by

$$s^6 + 2s^5 + 8s^4 + 12s^3 + 20s^2 + 16s + 16 = 0. \text{ Comment on location of roots and check the stability.}$$

$F(S) = S^6 + S^5 - 2S^4 - 3S^3 - 7S^2 - 4S - 4 = 0$. Find the number of roots falling in the RHS plane and LHS plane.

Draw the Nyquist plot for the system whose open loop transfer function is $G(S)H(S) = K/S(S+2)(S+10)$. Determine the range of K for which closed loop system is stable.

Construct Nyquist plot for a feedback control system whose open loop transfer function is given by $G(S)H(S) = 5 / S(1-S)$. comment on the stability of open loop and closed loop transfer function.

Sketch the Nyquist plot for a system with the open loop transfer function $G(S)H(S) = K(1+0.5S)(1+S) / (1+10S)(S-1)$. determine the range of values of K for which the system is stable.

6. The open loop transfer function of a unity feedback system is given by $G(S) = K / (S+2)(S+4)(S^2+6S+25)$ by applying the Routh criterion, discuss the stability of the closed loop system as a function of K. Determine the value of K which will cause sustained oscillations in the closed loop system. What are the corresponding oscillation frequencies?

Sketch the root locus of the system having $G(S)H(S) = K(S+2) / (S+1)(S+3+j2)(S+3-j2)$ for positive value of K.

Sketch the root locus for unity feedback system whose open loop transfer function is

$$G(s) = \frac{K(s^2 + 6s + 25)}{s(s+1)(s+2)}$$

Sketch the root locus plot of a unity feedback system with an open loop transfer function $G(s) = K / s(s+2)(s+4)$. Determine the value of K so that the dominant pair of complex poles of the system has a damping ratio of 0.5.

Sketch the root locus of unity feedback system whose open loop transfer function is $G(s)H(s) = K/s(s+4)(s^2+4s+13)$. Find the marginal value of K which causes sustained oscillations and find the frequency of these oscillations.

11. Sketch the root locus of the system having $G(s) = \frac{k(s+3)}{s(s+1)(s+2)(s+4)}$.

UNIT - V

1. The transfer function of a control system is given by $\frac{Y(s)}{U(s)} = \frac{(s+2)}{s^3 + 9s^2 + 26s + 24}$. Check for controllability.

2. Find the state variable equation for a mechanical system shown below.

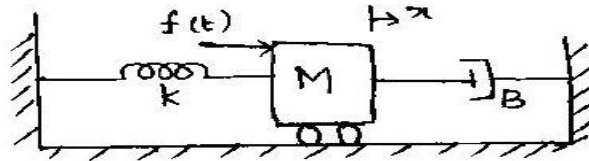

3. A system is characterized by the transfer function $\frac{Y(s)}{U(s)} = \frac{3}{s^3 + 5s^2 + 11s + 6}$. Identify the first state as the output. Determine whether or not the system is completely controllable and observable.

Explain the analysis of sampler and zero-order hold circuits.

Obtain the state transition matrix for the state model whose system matrix A is given by

$$A = \begin{bmatrix} 1 & 1 \\ 0 & 1 \end{bmatrix}$$

Determine the transfer matrix from the data given below.

$$A = \begin{bmatrix} -3 & 1 \\ 0 & -1 \end{bmatrix} \quad B = \begin{bmatrix} 1 \\ 1 \end{bmatrix} \quad C = [1 \ 1] \quad D = 0$$

The state space representation of a system is given below. Obtain the transfer function.

$$\begin{pmatrix} \dot{x}_1 \\ \dot{x}_2 \\ \dot{x}_3 \end{pmatrix} = \begin{pmatrix} -2 & 1 & 0 \\ 0 & -3 & 1 \\ -3 & -4 & -5 \end{pmatrix} \begin{pmatrix} x_1 \\ x_2 \\ x_3 \end{pmatrix} + \begin{pmatrix} 0 \\ 0 \\ 1 \end{pmatrix} u$$

$$y = (0 \ 1 \ 0) \begin{pmatrix} x_1 \\ x_2 \\ x_3 \end{pmatrix}$$

8. A system is characterized by the transfer function $\frac{Y(s)}{U(s)} = \frac{3}{s^3 + 5s^2 + 11s + 6}$. Identify the first state as the output. Determine whether or not the system is completely controllable and observable.

Write the state equation for the system shown below in which x_1, x_2 and x_3 constitute the state vector. Determine whether the system is completely controllable and observable.

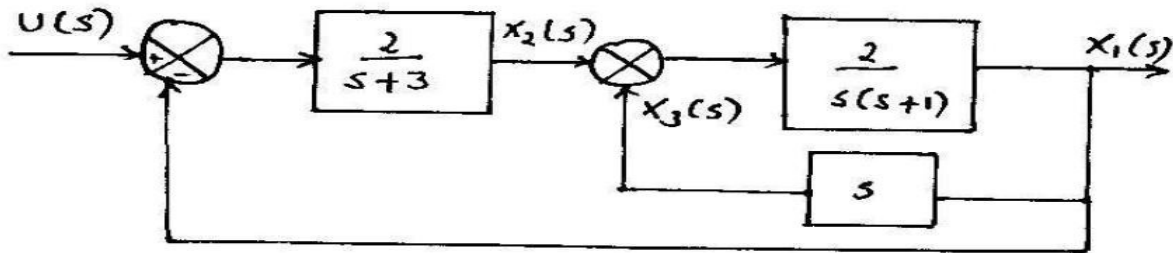

10. Obtain the state model of the system described by the following transfer function.

$$\frac{Y(s)}{U(s)} = \frac{5}{s^3 + 5s^2 + 6s + 7}$$

Determine the state model of armature and field controlled dc motor.

(i) Explain the analysis of sampler and zero order hold circuits.

⁰ Find the inverse Z- transform of $F(Z) = \{(3Z^2+2Z+1)/(Z^2-3Z+2)\}$.